



SIMPLE AURORA MONITOR

~SAM-III~

3-Axis Geomagnetometer

CONSTRUCTION MANUAL

Revision history on last page



SAM-III Construction Manual

Table of Contents

Section		Page
I.	Description	1
II.	General Building Tips	3
III.	Separate the Controller PCB and Keyboard PCB	4
IV.	Install Keyboard Components	5
V.	Install the Power Supply Components	7
VI.	Test the Power Supply	11
VII.	Install the Logic Circuits	13
VIII.	Install the Display Components	17
IX.	Install the Ribbon Cables	18
X.	Wire the EIA-232 Serial Port Cable	20
XI.	Testing and Adjusting	24
XII.	Load the Microprocessor Operating System Firmware	37
XIII.	SAM Display and Keyboard Reference Information	45
XIV.	Install the Controller, Keyboard and LCD in the Enclosure	48
XV.	Magnetometer Sensor Hookup	54
XVI.	Magnetometer Sensor Installation	64
XVII.	Temperature Sensor	70
XVIII.	Circuit Description	72
XIX.	SAM-III Kit Components Identification Guide	78
	Document History	85

SAM-III Construction Manual



I. Description

The 3-axis Simple Aurora Monitor magnetometer system (SAM-III) was designed by Dirk Langenbach (hardware) and Karsten Hansky (software). It is based on the 2-axis SAM. A schematic is provided at the end of this document.

The basis for the SAM-III is a fluxgate magnetometer sensor manufactured by Speake & Co Llanfapley. The sensor signals are processed on the signal processor module, which uses a Microchip PIC16F877 microprocessor. The microprocessor provides serial data, analog and alarm outputs. The basic specifications for the SAM-III magnetometer system are

- Range: Approximately ± 50000 nT
 - Resolution: 1 – 2 nT
 - Connection of 1, 2 or 3 sensors
 - Microprocessor controlled, 16 MHz clock
 - Data displayed on backlit 4x20 LCD (STN yellow/green standard)
 - Measured data transmitted over EIA-232 serial interface as ASCII text
 - K-Index available on one analog output (adjustable 0 ...+5 V or -2.5 ...+2.5 V)
 - Real-time clock with backup battery
 - Form A relay output for K-index alarm (maximum contact rating 200 V dc or V ac-peak, 1.0 a dc or a ac-peak, in a combination not exceeding 20 w)
 - Opto-isolated input for detection of external voltage condition to deactivate measurements
 - Software setup and measurement logging via EIA-232 serial interface
 - Power: 12 V dc at 60-100 mA (depending on number of sensors connected)
 - Dimensions (optional enclosure): 200 mm x 112 mm x64 mm
 - Temperature sensing capability
 - Connectors:
 - I/O: Pluggable terminal block, 8-pin
 - Sensor: Pluggable terminal block, 10-pin
 - EIA-232: DB-9M
 - dc power coaxial 2.1 mm x 5.5 mm, center +
 - Keyboard controls:
 - Command mode (F1)
 - Calibration mode (F2)
 - Software reset (F3)
 - Display backlight (F4)
 - Application software:
 - SAM_VIEW
 - SAM_INI
 - SAM_BROWSER
 - SAM_STAT
-

SAM-III Construction Manual

SAM and SAM-III

The primary differences between the SAM-II and SAM-III are:

1. Added third sensor
2. Added separate 78L05 voltage regulators for each of the three sensors
3. Added four NAND gates (74HCT00N) for multiplexing the third sensor
4. Eliminated one analog output (because of microprocessor I/O limitations) and changed output op-amp to LM358. The output shows K-Index and not magnetic induction
5. Replaced DIN connectors with pluggable screw terminal block headers
6. Replaced keyboard switches with surface-mount types
7. Added temperature sensor input (modifications no longer required)
8. Slightly smaller controller PCB
9. Replaced microprocessor firmware

A retrofit kit to convert existing SAM-II processor modules to 3-axis also is available. The modifications require replacing the microprocessor firmware and installing a small daughter-board on the main PCB, making hand-wired connection and, of course, hooking up a third sensor.

The latest versions of all existing application programs that were used with the SAM-II can be used with the SAM-III except that SAM-III requires a new SAM_INI program. Software setup is provided in the Software Setup Guide.

Building the SAM-III

If you build the SAM-III yourself: Before you start, you should first read through all manual sections and then follow them in order during construction. This will greatly reduce the chances of error. If you choose to build the SAM-III without following this manual, you do so at your own peril and greatly increase your chances of failure.

A components identification guide is included in this manual; see Table of Contents for page number.

If you purchased the build option (p/n BLD-1) with your SAM-III, the printed circuit boards (PCB) already are assembled as described in sections II through XII of this manual and the completed PCBs have been tested and burned-in for 24 hours. You should review sections II through XII and you also should read Sect. XIII to familiarize yourself with the SAM-III display and keyboard. After that, go to section XIV for installation of the display and PCBs in the optional enclosure (p/n EC-1). The remaining sections cover sensor installation and additional hardware information.

NOTICE: All parts in the SAM-III Kit are new. However, the reclosable (ziplock) bags holding the parts may be recycled. Your kit may include bags with extraneous writing or stickers on them. Ignore any such markings.

SAM-III Construction Manual

II. General Building Tips – READ THIS BEFORE STARTING:

- The SAM-III kit is built using conventional electronic construction techniques. All components are through-hole types except the pushbuttons on the keyboard, which are SMT
 - You will need a digital or analog multimeter to properly assemble and test this kit. It must be able to read resistance up to 500k ohms and voltage up to about 20 Vdc.
 - Before starting assembly, perform an inventory of all components – see the file *SAM Kit Parts List.xls* on the CD
 - Some parts are very small and easy to lose or may become tangled with other parts (for example, connector contacts), so be careful emptying the reclosable plastic bags and keeping track of the parts during inventory and during assembly
 - As you inventory the parts put them back into their bags so they are not lost
 - Resistors supplied with the kit may or may not have color coded stripes to indicate their value. The colors, if used, may have little contrast and be difficult to read. Confirm all resistor values with an ohmmeter
 - Use Sn63Pb37 or Sn60Pb40 solder with a diameter ≤ 0.031 in. (0.8 mm). For surface mount technology (SMT) use 0.015 in. (0.4 mm). Lead-free solder is not recommended except by builders with considerable experience using lead-free solder. Lead-free solder requires more heat and greatly increases the possibility of PCB and component damage, especially if any components have to be replaced after installation
 - Soldering component leads to the grounded pads may require a 60 W or greater soldering iron; only use a soldering iron with a very fine tip
 - Use a temperature-controlled soldering iron set to 315 to 350 °C; use the lowest temperature that works best with the solder and soldering iron tip. Cheap hobby-shop soldering irons are not recommended
 - Review online sources for soldering techniques if necessary
 - The parts required for construction are listed in a table at the beginning of each section. As each component or group of components is soldered and trimmed, place a checkmark in the boxes provided
 - READ ALL NOTES AND COMMENTS that follow the parts list in each section before assembling or soldering any components
 - To avoid the *porcupine effect*, install only three or four resistors or capacitors at a time. After soldering the small group of components, trim the extra lead lengths with a flush cutting wire cutter but leave a small extension of each lead below the PCB (approximately 1/16" or 1 or 2 mm)
 - After completing each section of the construction manual, use a magnifying glass and bright work light to examine each and every solder joint for inadvertent bridges or cold solder joint. Do not proceed with the next section until repairs are made
 - The leads of some components are taped together. Do not pull the leads out of the tape and then insert into the PCB. The tape gum may scrape off and make soldering difficult. There is plenty of extra lead so simply clip the part of the lead contacting the tape
 - Dual-inline (DIL) integrated circuits and their sockets will have a dimple or notch on one end and it must be oriented as indicated on the PCB silkscreen
 - Diodes have a bar or stripe on one end and it must be oriented with the bar indicated on the PCB silkscreen
 - Electrolytic capacitors are marked with a bar on one side, indicating the negative lead, and one of the leads is longer, indicating the positive lead. The positive (longer) lead must be inserted in the hole with a + symbol indicated on the PCB silkscreen
 - Leave all integrated circuits and other semiconductor devices in their anti-static carriers (pad and aluminum foil) until they are to be installed
 - Use anti-static protection whenever installing or handling integrated circuits and other semiconductor devices
 - After integrated circuits and other semiconductor devices are installed on the PCB, use electrostatic discharge (ESD) protection whenever handling the PCB
-

SAM-III Construction Manual

III. Separate the Controller PCB and Keyboard PCB

Required parts:

Parts list ID	Qty	Description
□	1	Printed circuit board

The printed circuit board (PCB) consists of two sections, which may be provided as separate pieces or joined by three small bridges (webs) or a v-groove. The image below shows PCBs joined by webs. The left portion is for the keyboard and the right portion is for the main controller. The PCBs have two sides, solder side and silkscreen side and may be colored green or blue.

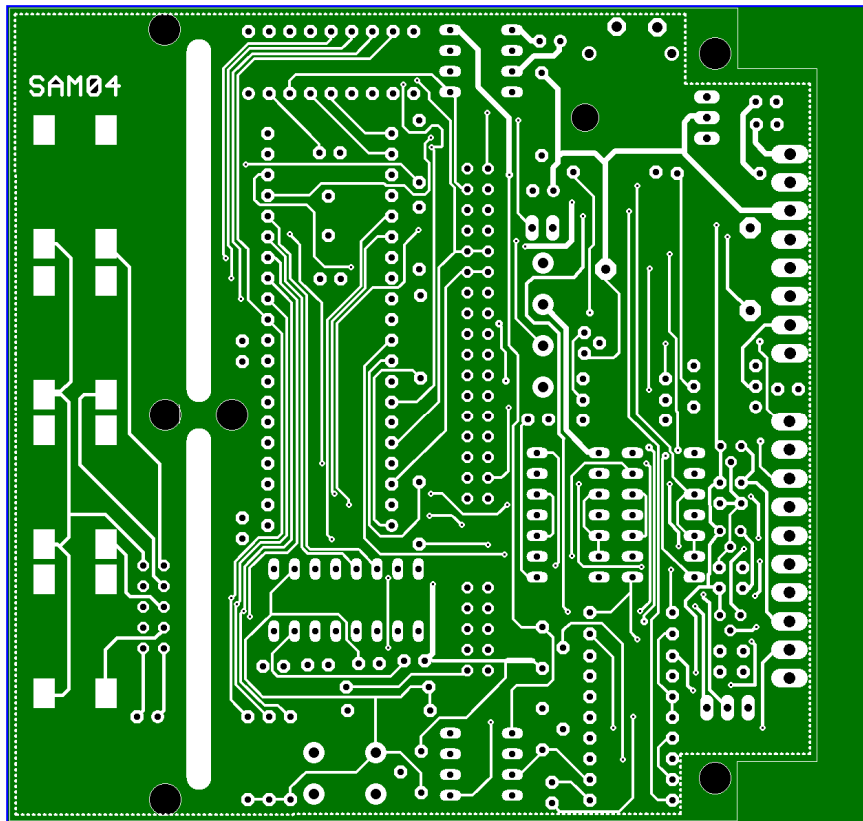

If the PCBs are joined by three webs, before placing any components, carefully cut the three small bridges between the controller PCB and keyboard PCB with a fine saw such as a modeler's saw. Do not attempt to break the two boards apart without cutting because the likelihood is very high the boards will be damaged. It is helpful to sandwich the PCB between two pieces of soft wood and clamp in a vise while cutting; do not clamp the PCB directly in the vise jaws.

If the PCBs are joined with a v-groove, they may be separated by gently bending the two sections until they break apart. After separating the two PCBs, the sharp edges can be removed and dressed with fine sandpaper or a file.

SAM-III Construction Manual

IV. Install the Keyboard Components

Required parts:

Parts list ID	Qty	Description
D5 <input type="checkbox"/>	1	LED, 3 mm, red ►
SV3 <input type="checkbox"/>	1	10-pin PCB header ►
S2 <input type="checkbox"/> , S3 <input type="checkbox"/> , S4 <input type="checkbox"/> , S5 <input type="checkbox"/>	4	Pushbutton (SMD)

► Indicates pay attention to polarity or direction

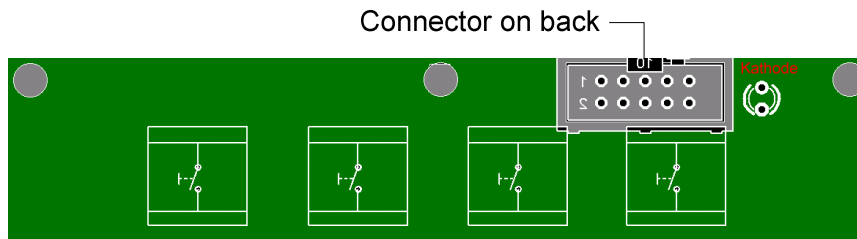

Install the four pushbuttons and red LED on the top (silkscreen side) and the ribbon cable socket on the bottom:

- Solder the four pushbuttons on the silkscreen side of the PCB. Use 0.015 in. (0.4 mm) diameter solder and a very fine soldering iron tip. The pushbuttons are the only surface-mount devices (SMD) in the kit. First, heat one of the pads for each pushbutton and place a very small amount of solder on it. Next, place one of the pushbuttons on the four pads, being very careful to center it. Then, hold the pushbutton in position and heat the pad with the solder on it – this will tack the pushbutton. Be sure the pushbutton does not shift when you tack it. If it does shift, simply reheat and adjust. Finally, solder the remaining three pads and then return to the first pad and add a little solder to complete the placement. See illustration (right)
- Repeat above for each pushbutton
- Solder the LED with shortest lead (cathode) in the hole nearest to the edge of the board. If the keyboard will be mounted in the optional enclosure, the body of the LED will have to be raised slightly. In this case, raise the LED enough so the flange at the bottom of the LED body is flush with the pushbutton body
- Turn the board upside down and insert the 10-pin PCB header with the CENTER aperture (center polarization slot) nearest to the edge of the board. Solder the pins on the top side. Note: Some 10-pin PCB headers have two slots, one on-center and one off-center. Be sure to align the ON-CENTER slot as specified
- Double-check all components for location and check polarity sensitive components (LED and PCB header)
- Double-check all soldering



When the keyboard PCB is finished it should look like the illustration below. Set the keyboard PCB aside.

SAM-III Construction Manual

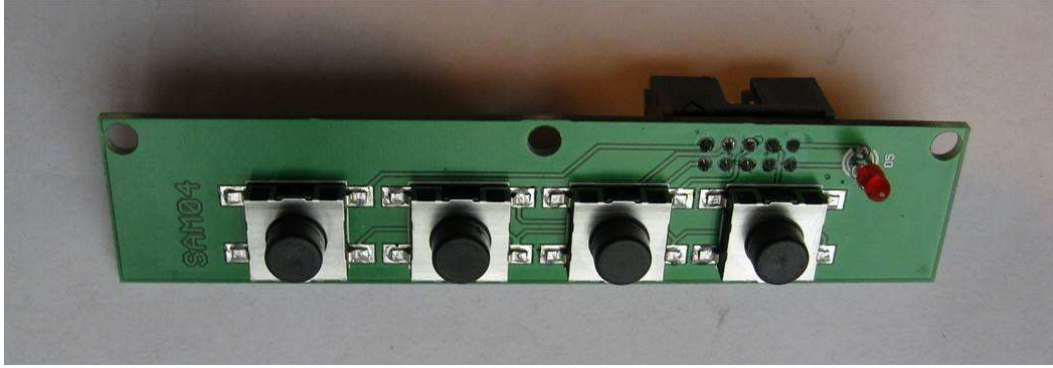

SAM-III Construction Manual

V. Install the Power Supply Components

Required parts:

Parts list ID	Qty	Description
R16 □	1	Resistor, 68R1 1/4 w
R2 □, R7 □, R9 □	3	Resistor, 1k, 1/8 w (1001)
R20 □, R22 □	2	Resistor, 2k2, 1/8 w
R1 □, R8 □, R10 □	3	Resistor, 10k, 1/8 w (1002)
R12 □, R14 □	2	Resistor, 10k, 1/8 w (1002)
R15 □	1	Resistor, 39k, 1/8 w
R3 □, R4 □, R5 □	3	Resistor, 100k, 1/8 w (1003)
R6 □, R11 □, R13 □	3	Resistor, 100k, 1/8 w (1003)
R17 □, R18 □, R21 □	3	Resistor, 100k, 1/8 w (1003)
R19 □	1	Resistor , 470k, 1/8 w (4703)
D1 □	1	Diode, 1N4007 ►
D2 □, D3 □	2	Diode, 1N4148 ►
D4 □	1	Diode, 1N5819 Schottky ►
C1 □, C2 □, C3 □	3	Capacitor, ceramic, 100 nF
C4 □, C5 □, C6 □	3	Capacitor, ceramic, 100 nF
C7 □, C8 □, C9 □	3	Capacitor, ceramic, 100 nF
C10 □, C11 □, C12 □	3	Capacitor, ceramic, 100 nF
C15 □, C16 □, C17 □	3	Capacitor, ceramic, 100 nF
C18 □, C21 □	2	Capacitor, ceramic, 100 nF
C13 □, C14 □	2	Capacitor, electrolytic, 10 μF/25 V ►
U5 □	1	Voltage converter, ICL7660, -5 V out ►
U2 □	1	Voltage Regulator 7805, TO-220, +5 V/1 A
□	1	4-40 x 5/16 in. screw, washers & nut
U1 □, U3 □, U4 □	3	Voltage Regulator 78L05, TO-92, +5 V/100 ma
G1 □	1	Lithium battery, 3 V, 3-pin
X1 □	1	PCB header socket, 8-position
X2 □	1	PCB header socket, 10-position
XP1 □	1	Pluggable screw terminal block, 8-position
XP2 □	1	Pluggable screw terminal block, 10-position
□	1	PCB header, 3-position, 2 pin (1-0-1 configuration) ►
□	1	Connector socket housing, 3-position, black
□	2	Terminal socket contact, box type
□	1	24 AWG wire, 15 cm long, orange
□	1	24 AWG wire, 15 cm long, green
□	2	Heat shrink tubing, ~10 mm long
□	1	Coaxial power jack, 2.1 x 5.5 mm, panel mount ►
□	1	Coaxial dc power plug, 2.1 x 5.5 mm
□ ac power adapter	1	12VDC/200 mA (not supplied except as accessory)
□ IC socket	2	14-pin x 0.3 in. DIL (not supplied) ►
□ IC socket	2	8-pin x 0.3 in. DIL (not supplied) ►
□ IC socket	1	16-pin x 0.3 in. DIL (not supplied) ►
□ IC socket	1	18-pin x 0.3 in. DIL (not supplied) ►
□ IC socket	1	6-pin x 0.3 in. DIL (not supplied) ►

► Indicates pay attention to polarity or direction

SAM-III Construction Manual

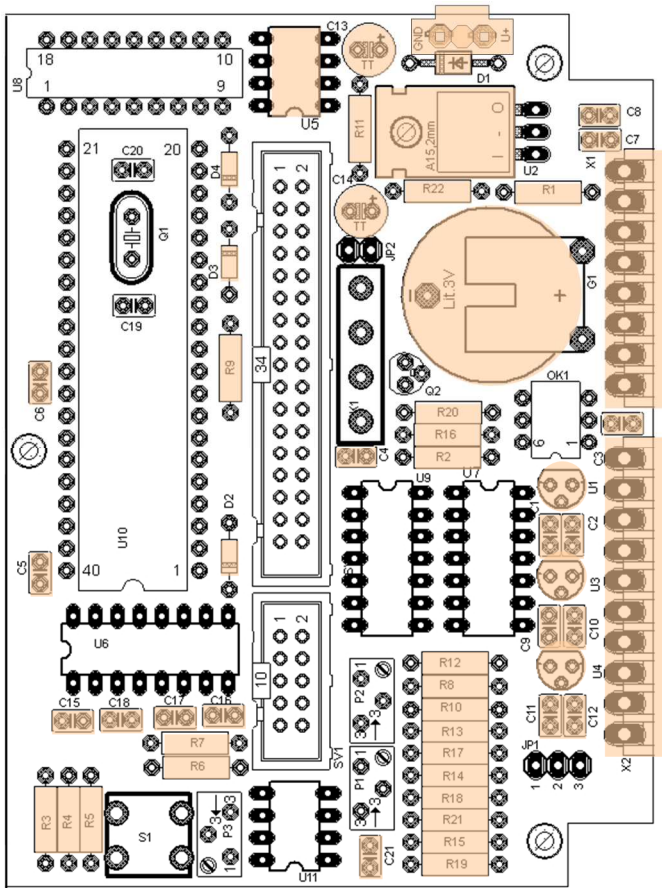

Install all listed components on the top (silkscreen) side of the PCB and solder at the bottom. A larger image of the PCB is shown in Sect. XIX.

- Solder all resistors
- Solder the diodes. Diodes are polarity sensitive and must be installed with the proper orientation. The bar or stripe on one end of the diode indicates the cathode and it must correspond with the bar on the PCB silkscreen. Do not install D1 (1N4007) flush with the PCB; extend it above the board about 2 mm so it can be bent slightly to one side to make more room for the power connector that is installed next to it
- Solder all 100 nF ceramic capacitors (these capacitors are not polarity sensitive and may be placed either direction)
- Solder the voltage regulator U2. To avoid damaging stress, do not bend the leads on U2 at the body; bend them about 1 or 2 mm away from the body. The leads should be bent so the TO-220 tab can lie flat on the PCB with the holes lined up. Use 4-40 hardware (supplied) to mechanically secure the tab; insert the screw with a flat washer from the bottom of the PCB and install a flat washer, split lock washer and nut on the top
- Solder the integrated circuit voltage regulators U1, U3, U4 and U5, observing their proper orientation. Some builders prefer to install U5 in a dual-inline (DIL) socket (see next step)
- If you plan to use DIL sockets with the integrated circuits, install them now. DIL sockets are not supplied with the kit. DO NOT install the 40-pin socket for the microprocessor U10 at this time. Note: A 6-pin DIL socket can be made from an 8-pin or larger socket by cutting it down
- Solder the two electrolytic capacitors; these capacitors are polarity sensitive and must be installed with the proper orientation. The bar marked on the side of the capacitor indicates the negative lead, and the longest lead is the positive. Be sure to put the long lead in the hole marked with the + polarity

SAM-III Construction Manual

- ❑ Solder the pluggable terminal blocks. The holes are very slightly oversized, so take care to align the terminal blocks parallel to the PCB edge. Tack one lead and check that the terminal block is flat against the board and the edge is parallel. Correct before soldering the remaining terminals
- ❑ Solder the battery. The battery fits only one way. The battery terminals are VERY thin and fragile. Be VERY careful handling the battery. DO NOT set it on a conductive surface and DO NOT short it out. Note: The + terminal of the battery has two pins on the edge and the – terminal has one pin. Your SAM-III Kit includes one of two battery types, with slightly different spacing between the + and – terminals. The PCB may be equipped with one or two holes for the – terminal. If the PCB has one hole, it may be necessary to slightly bend the battery – terminal so that it fits the PCB. Center the battery on the silkscreen circle on the PCB
- ❑ Solder the 3-position, 2-pin power header into position adjacent to diode D1. Some kits are supplied with a latching (polarized) header. The latching header should be installed so the latch is facing away from the PCB
- ❑ FROM THIS POINT FORWARD, DO NOT SET THE PCB ON A CONDUCTIVE SURFACE – YOU MAY SHORT OUT THE BATTERY AND DAMAGE THE PCB OR BATTERY OR BOTH
- ❑ Assemble the dc power cable. Crimp (if you have the proper tool) or solder the orange and green hookup wires to the box type socket contacts (right) for the 3-position socket connector and inset into the 1st and 3rd position on the connector. There is a small tab on the contacts that catches in the slot on one side of the connector, so be sure to insert them with the correct orientation. Solder the two wires to the coaxial dc power jack as shown in the drawing below. Observe polarity. Note: Some PCB power connectors have a mechanical polarizing latch and tab; see drawing on the next page for wiring. If the connector does not have a latch, put a drop of red fingernail polish or tape on the + side of the connector (adjacent to orange wire) and on the PCB
- ❑ Connect the finished power cable assembly to the PCB power input header pins. Observe polarity
- ❑ Double-check all components for location and check polarity sensitive components (electrolytic capacitors, diodes, battery), voltage regulators and integrated circuits for proper orientation.
- ❑ Double-check all soldering
- ❑ If you installed IC sockets, be sure that only U5 (ICL7660) is plugged in at this time. No other ICs should be installed

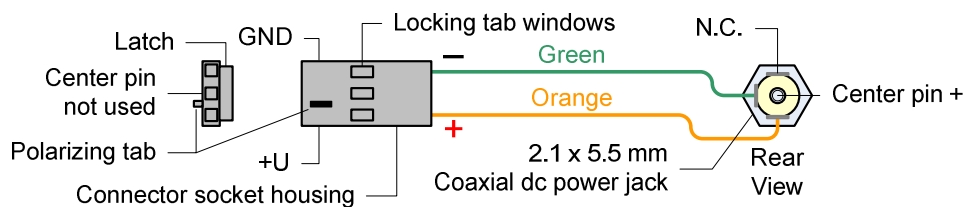
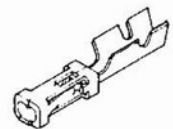

SAM-III Construction Manual

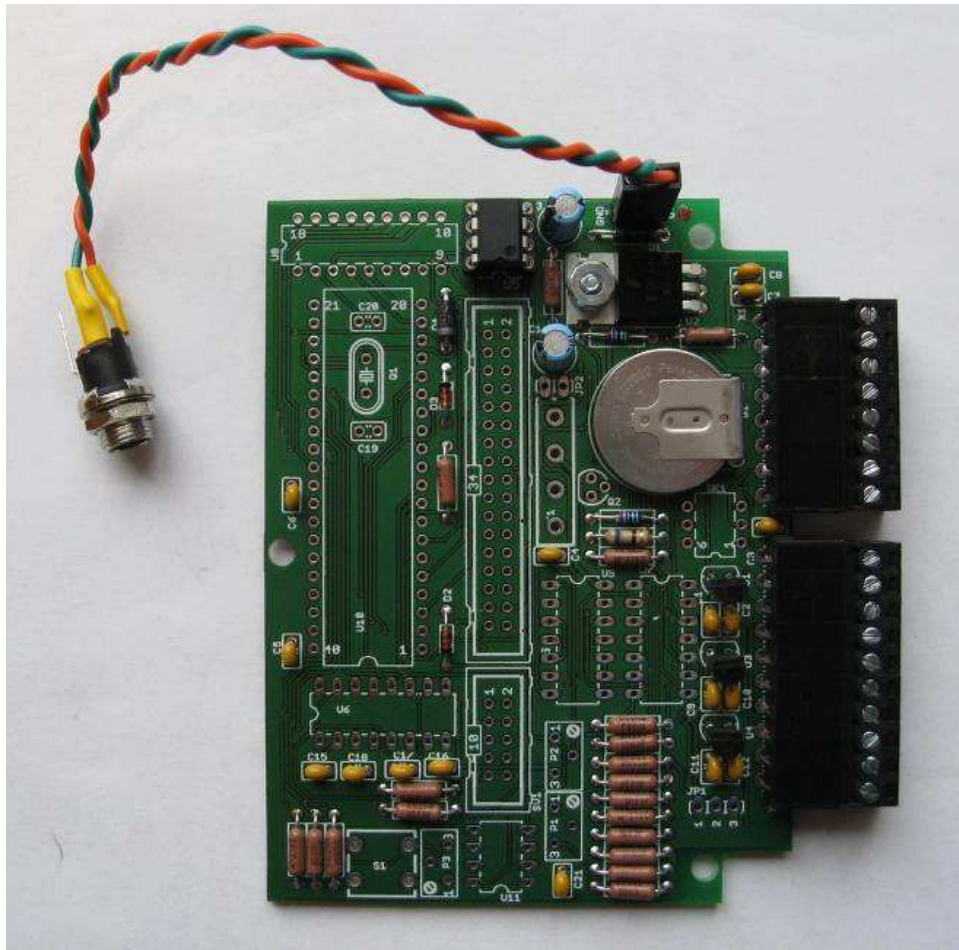

SAM-III Construction Manual

VI. Test the Power Supply

The SAM-III power supply components are now ready to test. You will need a suitable power source such as an ac power adapter or bench power supply.

AC power adapters are a huge source of problems because they generally are very cheaply built and many are poorly designed. If you purchased your SAM-III with an ac adapter (North America customers only), you received a quality brand with sufficient capacity.

The power supply or ac adapter should have the following characteristics

- Output voltage within the range of: 9 to 17 Vdc when under load
- Output current: ≥ 200 ma

If you supply your own ac adapter its output must be rated at least 9 Vdc, 200 mA under load. DO NOT attempt to power the SAM-III with an under-rated ac adapter. DO NOT use an ac adapter with an output higher than approximately 17 Vdc when under load. The 7805 and 78L05 voltage regulators used in the SAM-III have a maximum input voltage rating of 35 Vdc but you should allow for a margin of 1/2. Similarly, the SAM-III input current draw is approximately 60-100 mA (fully built with sensors connected) but you should allow for a margin of at least 2.

DO check your ac adapter leads for polarity with a voltmeter before connection. If you connect the power adapter backwards, you probably will not hurt anything but, of course, the SAM-III will not work. The SAM-III includes a reverse polarity guard diode (D1). The center pin of the coaxial power connector is positive.

- Connect the 12 Vdc power source to the coaxial power connector and then plug the power supply or ac adapter into an ac receptacle.

With a multimeter set to the 20Vdc range, check the following voltages with respect to ground (refer to illustration below). Connect the meter negative (black) lead to ground and then probe the measurement points with the meter positive (red) lead:

	Nominal voltage	Measured range	Remarks
<input type="checkbox"/>	+5 V dc	+4.75 to +5.25 V	Determined by 7805 or 78L05
<input type="checkbox"/>	-5 V dc	-4.75 to -5.25 V	Determined by ICL7660
<input type="checkbox"/>	+3 V dc	+3.2 to +3.4 V	New battery, no load
<input type="checkbox"/>	+12 V dc	+11 to +19 V	Actual input voltage less ~ 0.7 V
	Input current		
<input type="checkbox"/>	~ 10 mA dc	10 – 12 mA	Nominal

Note: Turn the screws on the pluggable terminal blocks down before touching the meter probe to them; otherwise, the screws do not make contact

SAM-III Construction Manual

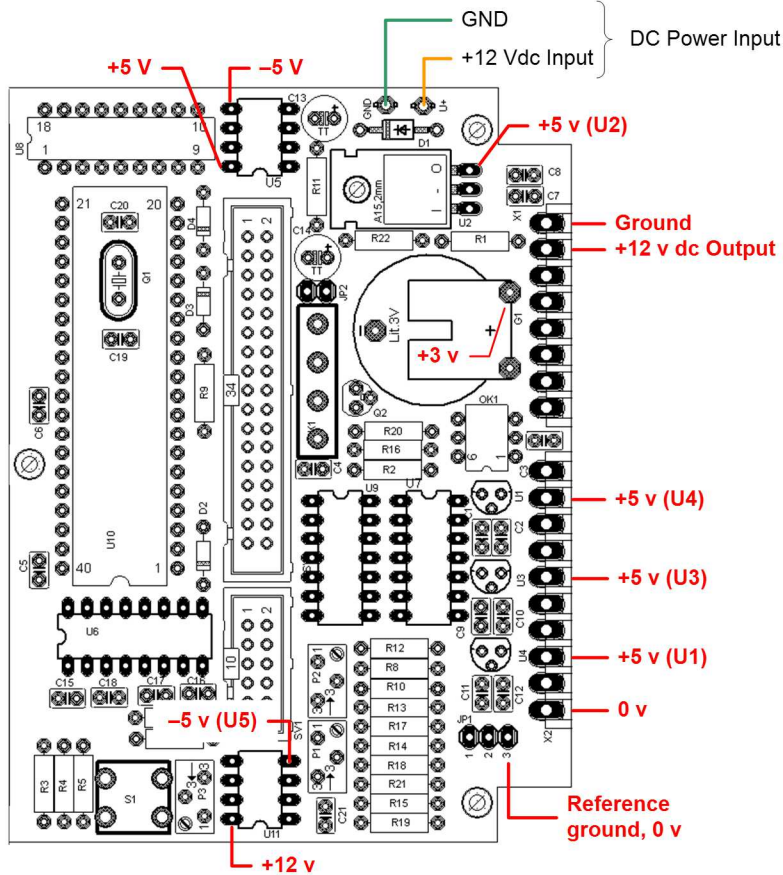

If all voltages are within the specified ranges, the power supply components are working properly. Remove the dc power before continuing!

If the voltages or load current are not within the specified ranges, check for shorts, solder bridges and orientation of polarity sensitive components (electrolytic capacitors, diodes, and voltage regulator ICs). Do not continue until you have fixed the problem.

SAM-III Construction Manual

VII. Install the Logic Circuits

Required parts:

Parts list ID	Qty	Description
C19 □, C20 □	2	Capacitor, 22pF
U7 □, U9 □	2	NAND-Gate 74HCT00 logic IC ►
U6 □	1	MAX232 transceiver IC ►
□	1	DIL 40-pin IC socket, see below ►
U10 □	1	Microprocessor PIC16F877 IC ►
JP1 □	1	3-pin polarized header block ►
JP2 □	1	2-pin header block
K1 □	1	Reed relay, 5 V ►
OK1 □	1	Opto-coupler CNY17F ►
P1 □	1	Variable resistor 47k or 50k
P2 □, P3 □	2	Variable resistor 10k
Q1 □	1	Crystal, 16MHz / HC49U-V
Q2 □	1	Transistor, BC337
S1 □	1	Reset pushbutton
SV1 □	1	10-pin polarized PCB header socket
SV2 □	1	34-pin polarized PCB header socket
U11 □	1	Op-amp IC, LM358N ►
U8 □	1	Real time clock IC, RTC72421 ►

► Indicates pay attention to polarity or direction

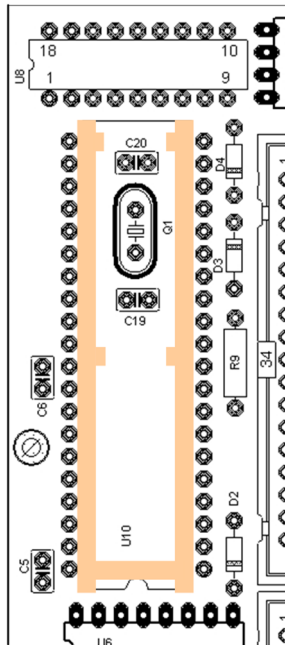

- Locate the 40-pin IC socket and the two crystal oscillator capacitors (C19, C20, both 22 pf). Test fit the three components. If the capacitors are small enough and their tops are below the IC socket web, then no modifications to the socket are required. Solder the IC socket in position with the small notch at the end near U6, then skip the next step. If the tops of the capacitors are above the socket web, it is necessary to modify the socket. Go to the next step
- If the tops of the capacitors are above the socket web, it is necessary to cut two plastic bridges so that the two capacitors can be bent over. At one end of the socket there is a small notch. At the opposite end (the end without the notch), carefully cut the bridge out of the frame and also cut the center bridge (see illustration); use a thin hobby saw and be very careful not to damage the pins or break the plastic structure. Solder the IC socket in position with the small notch at the end near U6

SAM-III Construction Manual

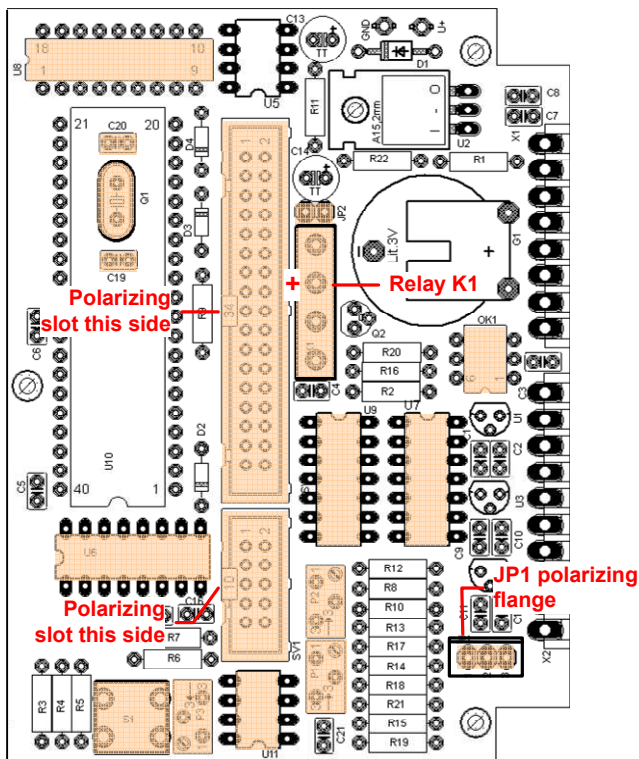
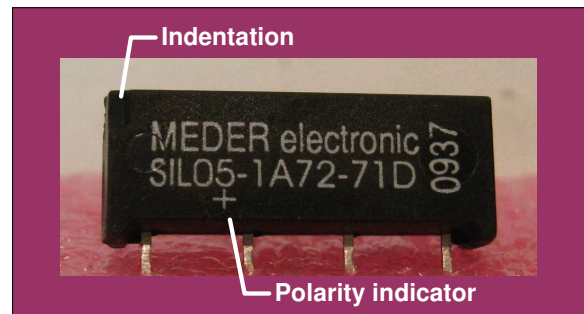

- Solder the two headers JP1 and JP2. JP1 has a polarizing flange on one side and it must be installed with the flange toward the pluggable terminal block as shown in the illustration above. JP2 is a simple 2-pin header and must be installed with the shorter pins soldered to the PCB
- Solder the PCB header sockets SV1 and SV2. The CENTER polarizing aperture (center polarizing slot) must be on the side toward the 40 pin IC socket
- Solder the variable resistor P1 (47k or 50k)

SAM-III Construction Manual

- Solder the variable resistors P2, and P3 (10k)
- Solder the reset pushbutton S1 (either way)
- Locate the reed relay K1 and hold it with the pins down and the text facing you. There is a small dimple or indentation on the upper-left corner. See illustration. The relay has an internal diode across the coil winding to prevent inductive kickback, so it is polarity sensitive. Place the relay on the PCB so the + mark on the relay corresponds with the + on the PCB illustration above; the text on the relay must be on the side toward the 34-pin header. The relay location is marked K1 on the PCB silkscreen but only the 1 is visible
- Solder ICs U6 (MAX232E), U7 (74HCT00), U8 (RTC72421), U9 (74HCT00), U11 (LM358N) and OK1 (CNY17F) and transistor Q2; Match the dimple on the end of each IC with the silkscreen on the PCB. Some CNY17F, OK1, have a depression along the side with pin 1. Some builders prefer to install DIL sockets (not supplied) rather than solder the ICs directly to the PCB; if so, install them now
- Solder the ceramic capacitors C19 and C20. If you had to modify the 40-pin DIL socket by cutting the webs, bend the capacitors flat on the PCB away from the crystal location and then solder
- Check the bottom of the crystal (Q1). If it does not have a thin insulating wafer, cut one from a piece of paper. The wafer or paper raises the crystal a little above the PCB and prevents it from touching the traces. Solder crystal Q1. DO NOT overheat the crystal as it could be damaged

All controller PCB soldering is done.

- Install the 40-pin microprocessor U10 (PIC16F877) in its socket. Install all other ICs if you used sockets. Be very careful to not bend the pins when inserting in the socket (it is quite easy to bend a pin underneath the IC body). Use static protection when handling ICs and observe proper orientation of the notch or dimple in the IC.
- Note: Most ICs are shipped with the leads bent at a slight angle away from the body. Before attempting to insert them into a socket carefully bend the leads so they are at a right-angle to the body. To do this, grip the IC at both ends and lay one side of the IC with the pins on a flat, smooth surface. Carefully rotate the body toward the pins a few degrees so the pins are uniformly bent at a right angle to the IC body. Flip the IC over and repeat on the other side.
- Double-check all components for location and check polarity sensitive components (electrolytic capacitors, diodes, battery), voltage regulators and integrated circuits for proper orientation.
- Double-check all soldering for bridges, shorts and cold solder joints

The controller board should now look similar to the pictures below (some components may look slightly different). Set the controller PCB aside but do not set it on a conductive surface.

SAM-III Construction Manual

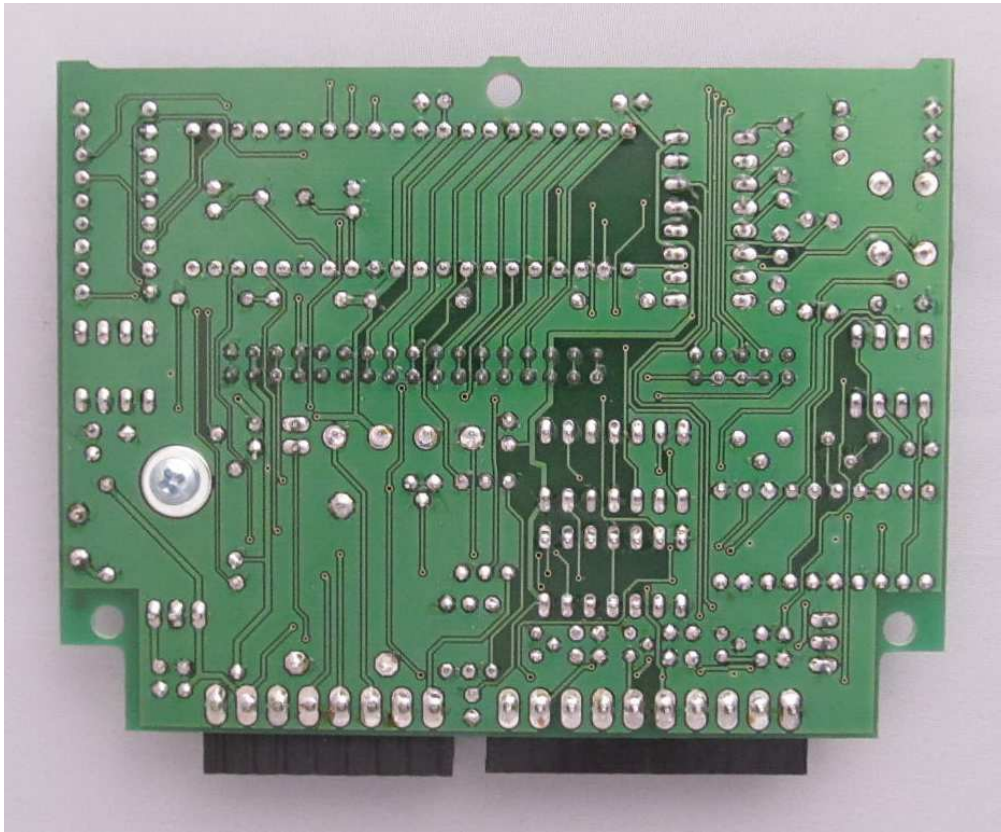

SAM-III Construction Manual

VIII. Install the Display Components

Required parts:

Parts list ID	Qty	Description
LCD1 <input type="checkbox"/>	1	Display module (LCD)
SV1A <input type="checkbox"/>	1	34-pin PCB header



- Some LCD modules are shipped with the 34-pin PCB header ribbon cable connector already installed. If not, remove the two end pins of the 34-pin header so that it will fit the 16 holes in the PCB. See illustration above. Pull the pins from the back (PCB) side
- Place the LCD module on a soft cloth with the display facing down
- Insert the 34-pin header as shown so that the center polarizing slot is facing out. When properly oriented, the cut off pins will be in the middle of the LCD module, and the row of pins closest to the polarizing slot will rest against the board edge. See illustration below
- Carefully solder the 16 pins

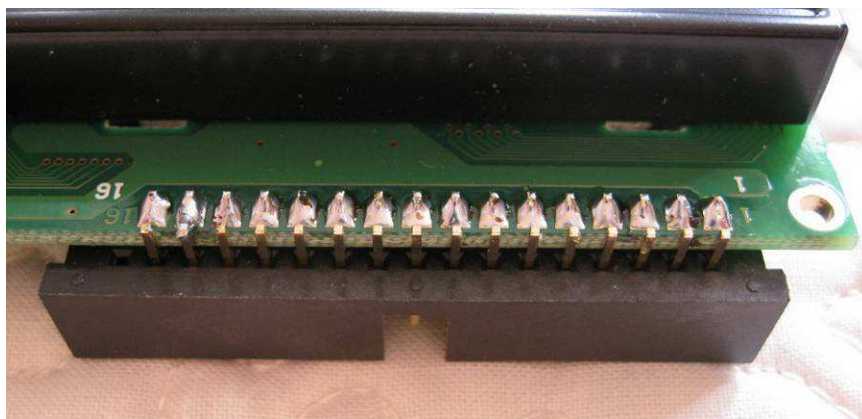

All printed circuit boards are now done.

SAM-III Construction Manual

IX. Install the Ribbon Cables

Required parts:

Parts list ID	Qty	Description
W2 <input type="checkbox"/>	1	34C ribbon cable, 10-15 cm long
W3 <input type="checkbox"/>	1	10C ribbon cable, 10-15 cm long
JS2A <input type="checkbox"/> , JS2B <input type="checkbox"/>	2	34-pin ribbon cable mount connector with strain relief
JS3A <input type="checkbox"/> , JS3B <input type="checkbox"/>	2	10-pin ribbon cable mount connector with strain relief

- The two ribbon cables, one with 10 conductors and one with 34 conductors, may require assembly or may have the connectors already installed. If the connectors are not already installed, assemble the two cables with a connector at each end. Align the red conductor with pin 1 on both connectors
- See illustrations below:
- (left) 10C cable shown with red conductor at top
- (right) Connector top and front view shows position of pin 1 on 10-pin connector. The first and last pins are marked on the front of the connector but the numbers cannot be seen without a magnifying glass. The 34-pin connector has the same configuration
- Insert the cable between the cable clamp and the connector body with the red conductor on the side where pin 1 is located. Squeeze the clamp and body together in a small vise. If necessary, cover the vise faces with hard wood to keep from marring the connectors. Be careful to align the cable at right angles to the clamp and body. After assembly, trim the cable with a razor blade or hobby knife
- After the connectors are installed, fold the cable over the top of the connector and snap the strain relief into place

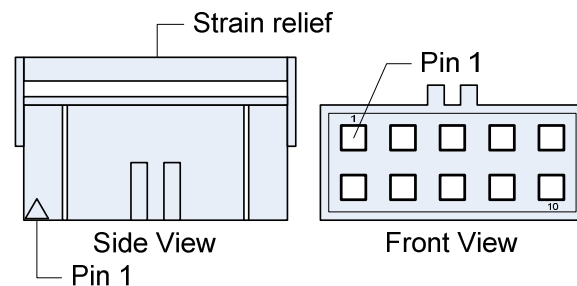
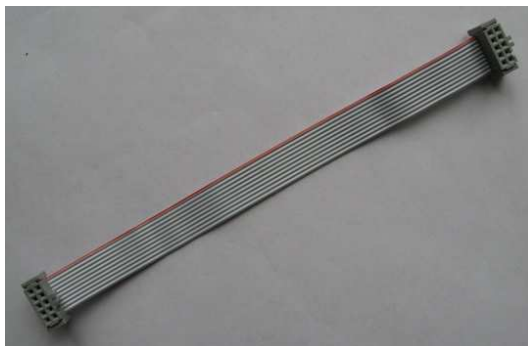

SAM-III Construction Manual

- Lay the boards as shown in the illustration below with the 34-pin and 10-pin headers facing up

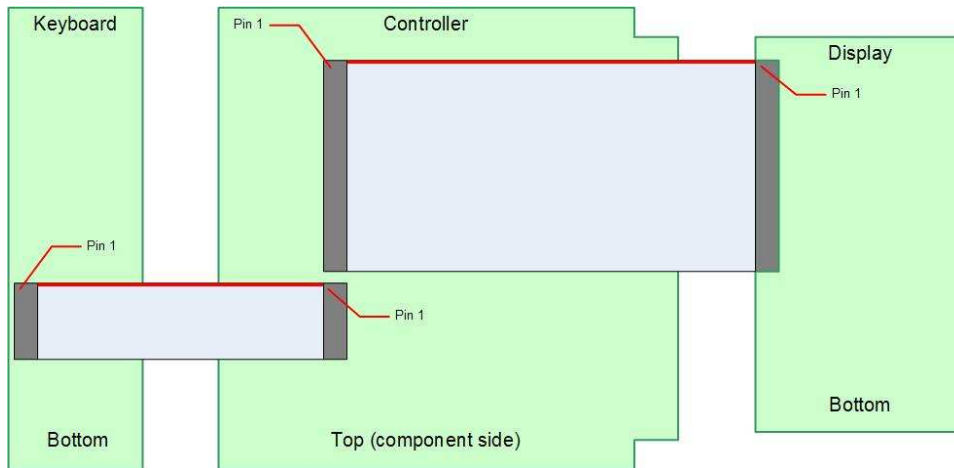

- Carefully insert the connectors in the sockets. They will fit only one way
- Turn the three boards over

SAM-III Construction Manual

X. Wire the EIA-232 Serial Port Cable

This section describes several serial port configurations. The first one, described immediately below, wires the SAM serial port as Data Terminal Equipment (DTE) with a DB-9M connector. This requires a null modem cable (supplied with kit) in which pins 2 and 3 are reversed on one of the connectors. One of the other configurations wires the SAM serial port as Data Communications Equipment (DCE) so that it can be connected to a PC with a straight-through cable and not a null modem cable. The third configuration uses a 3.5 mm stereo phone jack to save panel space.

Required parts:

Parts list ID	Qty	Description
JP4 <input type="checkbox"/>	1	DB-9M plug
JS1 <input type="checkbox"/>	1	Socket connector housing, white ►
<input type="checkbox"/>	3	Terminal contact, spring type
<input type="checkbox"/>	1	24 AWG wire, 15 cm long, red
<input type="checkbox"/>	1	24 AWG wire, 15 cm long, black
<input type="checkbox"/>	1	24 AWG wire, 15 cm long, green

► Indicates pay attention to polarity or direction

- Tin the solder cups of the DB-9M connector
- Solder a wire to pins 2, 3 and 5 on the DB-9M connector JP4 using the color code shown in the schematic below. Twist the three wires together and trim the leads to the same length. The supplied wires can be shortened if the DB-9M connector is mounted close to the PCB.

SAM-III Construction Manual

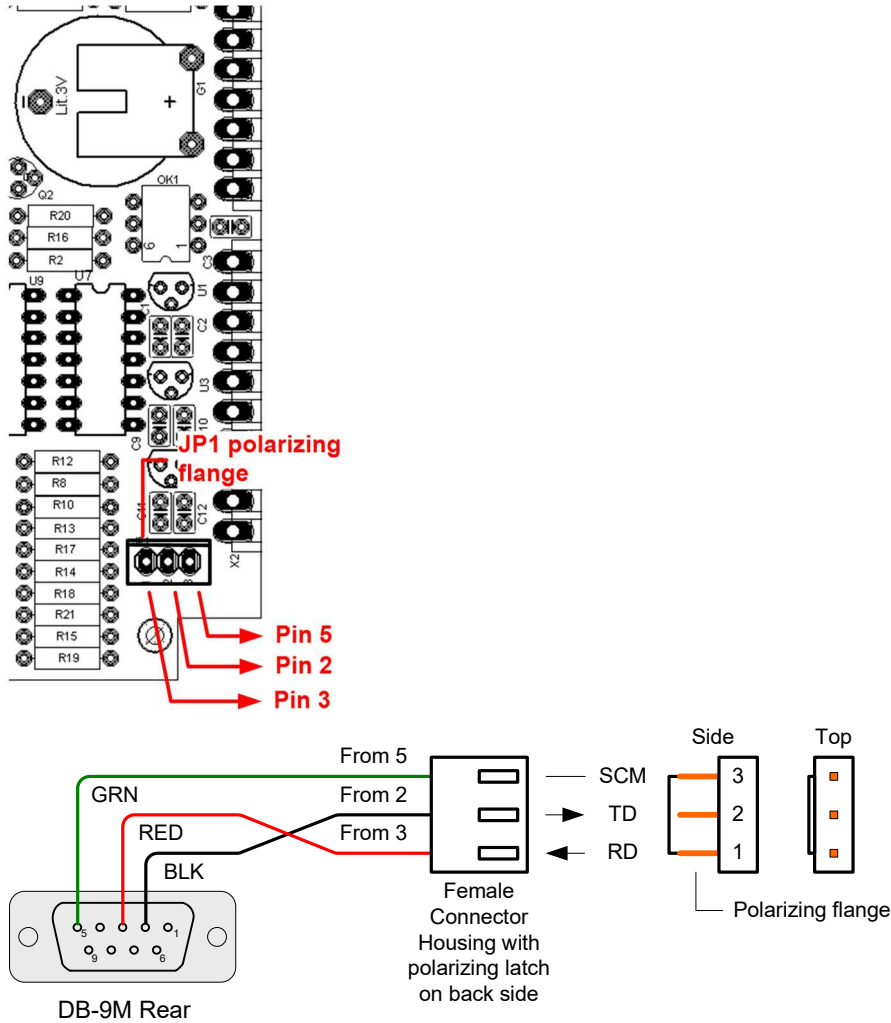

- Crimp (if you have the proper tool) or solder each wire from the DB-9M connector to a spring type contact (right). Use the wire color to identify the pin on the DB-9M connector and insert into the female connector housing JS1 in the proper order. The PCB header JP1 has a polarizing flange and the female connector housing JS1 has a corresponding latch. 
- Install the serial port cable JS1 on the controller PCB JP1. It will fit only one way.

SAM-III Construction Manual

Alternate Arrangements for Serial Port Connector:

The following paragraphs describe two alternate arrangements for the serial port connector.

Alternate arrangement 1: This arrangement replaces the supplied DB-9M connector with a DB-9F and wires it in a DCE configuration. The advantage is that the SAM-III can be connected directly to a PC serial port (or USB/EIA-232 adapter) without a null modem cable. Instead, a straight-through cable may be used that has a DB-9M plug at one end (SAM-III) and DB-9F plug at the other end (PC). Even though a null modem cable is supplied with the SAM-III Kit, some users may prefer using this more common arrangement. The drawing below shows the alternate wiring arrangement.

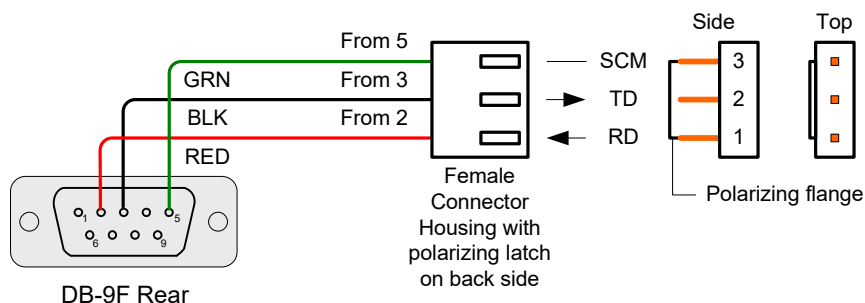

Alternate arrangement 2: This arrangement saves a little panel space and does not require cutting an odd-shaped hole for a DB-9 connector. Use a regular 3.5 mm stereo phone jack for the connector on the SAM-III enclosure as shown in the drawing below.

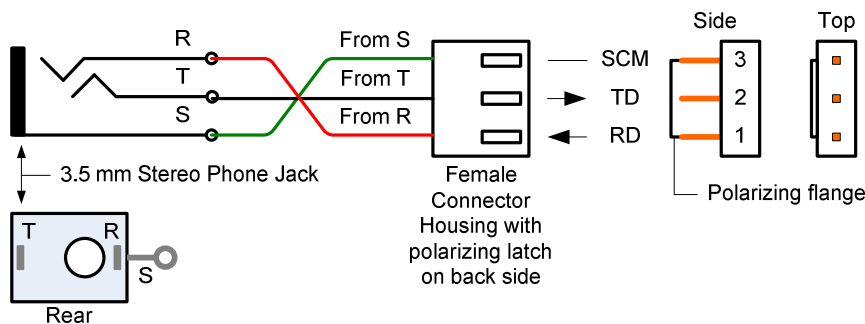

Of course, a cable with DB-9 connectors at each end will not work with this arrangement for connecting the SAM-III to a PC, but an existing cable with at least one DB-9F connector can be easily modified. Cut off one of the connectors (retain one DB-9F on the cable) and wire the cable blunt end to a 3.5 mm stereo plug as shown in the drawing below.

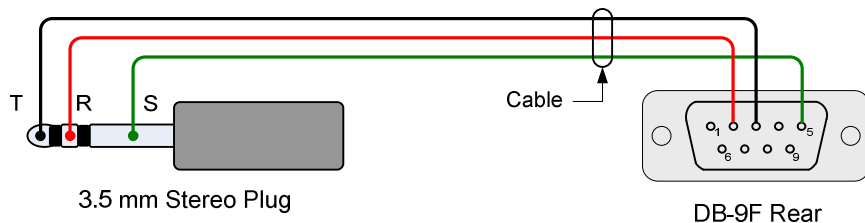

Some data loggers (for example, the Onset Computer HOBO and Omega Engineering data loggers) use the same configuration, so users with these data loggers already have a cable and do not need to make one.

SAM-III Construction Manual

SAM-III Construction Manual

XI. Testing and Adjusting

Required parts:

Parts list ID	Qty	Description
<input type="checkbox"/>	1	EIA-232 null modem cable, DB-9F/DB-9F
<input type="checkbox"/>	1	Header shorting block
<input type="checkbox"/>	1	AC power adapter, 12 Vdc, 200 mA (user supplied or optionally provided for North American customers)

The microprocessor has testing firmware (IB3_ENG.HEX) preinstalled that allows display and interface testing and adjustment. The following sections test all functions and interfaces except the magnetometer sensors. The operating system firmware (SAM3_ENG.HEX) and sensors will be installed and tested later.

Connect the LCD module, keyboard, power connector and EIA-232 serial port connector to the SAM-III PCB as shown below. Do not connect anything to the Aux Controls plug (X1) or Sensors plug (X2) at this time.

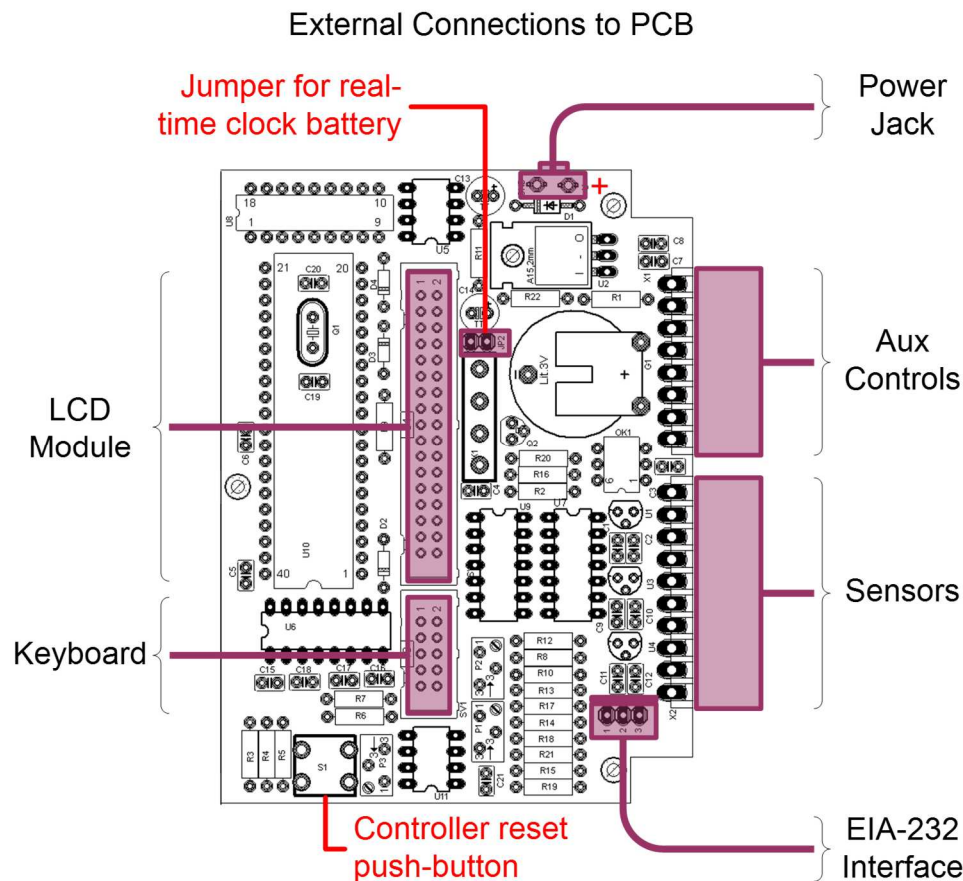

Install the shorting block on JP2 to activate the internal real time clock battery

SAM-III Construction Manual

□ Connect the null modem cable (supplied) between the SAM-III controller DB-9M connector and the serial COM port on the computer. Note: The null modem cable uses only pins 2, 3 and 5 on the DB-9F connectors, and the conductors for pins 2 and 3 are reversed on one of the connectors

A USB-serial interface adapter is required if your PC does not have a built-in serial port. If you use an adapter, do not go any further in this document until you download and install the latest USB-serial device drivers for your operating system. This is especially important with Windows 7. Upgrade your drivers NOW.

In order to use the PIC loader program supplied with the SAM-III kit, the USB adapter must support COM1, COM2, COM3, COM4, COM5 or COM6. The drivers supplied with most USB adapters allow the COM Port to be set in this range. It may be necessary to use Advanced settings in Windows Device Manager (Port Settings tab) to set the port within this range. If you change the port settings, be sure to “bounce” (unplug and the re-plug) the USB-serial adapter for the new settings to take effect. For additional information on USB port management:

http://www.reeve.com/Documents/Articles%20Papers/USBPortManagement_Reeve.pdf

DO NOT proceed until you have verified that you have the latest drivers for your USB-Serial Adapter. This is especially important if you are using Windows 7. Check for the latest drivers now.

Initial Power Up

Connect the ac power adapter to the SAM-III controller board and plug the ac adapter into an ac outlet receptacle. The LCD probably will not show anything at this time. With no sensor connected, the current draw will be around 50 mA with the LCD backlight on and around 30 mA with it off. If the keyboard LED is on, it will add about 10 mA load. Each sensor will add around 15 mA; however, at this time the sensors should not be connected.

As already mentioned, the test firmware (IB3_ENG.HEX) is preinstalled. With that firmware and power applied to the PCB, the LED on the keyboard will flash at ~2 Hz rate.

Adjust the LCD Contrast

The LCD contrast is adjusted by 21-turn potentiometer P3 (see illustration below). Slowly adjust P3 until the display letters turn dark. Considerable adjustment may be needed. Continue turning slowly until the display background just changes (background pixels start to show) and then back-off the adjustment just enough so the background disappears. This setting provides good contrast for the present lighting conditions. It may be necessary to readjust the contrast when you move the SAM-III to a new location.

If you have problems obtaining a display, proceed as follows: Measure the contrast voltage on the center (slider) of potentiometer P3 (pin 3 on the LCD connector, pins 5-6 on the schematic). You should be able to adjust the voltage from 0 to 5 V with P3. Voltage measurements on a lab system with good contrast on the display showed 0.9 V. When it was adjusted to 1.5 V, the display disappeared. You can save some trouble by turning the P3 adjustment screw at least 21 turns to the full counter-clockwise (CCW) position. It does not have a mechanical stop but you will hear a faint click when it reaches the full CCW position. Now, slowly adjust clockwise (CW) to adjust the display contrast. The lab systems required adjusting 3-4 turns CW from the full counter-CCW position.

The display should now read:

SAM-III Construction Manual

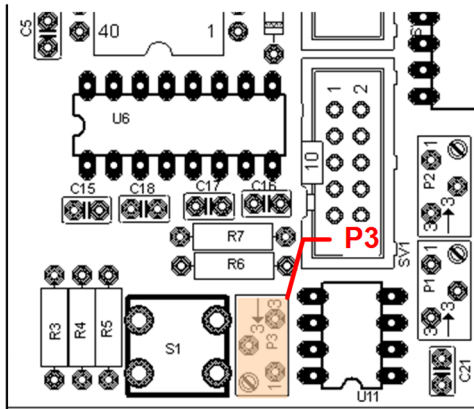

SAM - Simple Aurora
Monitor
by DG3DA & DL3HRT
Initial tests

or, more likely, if the initial screen timer expired during display adjustment, it will read:

Keyboard:
Successively press
F1-F4...

You can view the initial screen anytime by press the reset pushbutton (S1) on the controller PCB. This will reboot the SAM-III controller and start over. In the following tests, you may press S1 anytime you would like to return to the initial screen and start over.

If you have problems, measure the Vcc pins on the ICs. You will have to refer to the schematic to determine the pins. Also, measure the current drawn by the SAM-III. It should be nominal 50 mA. A current draw significantly higher or lower indicates a problem with a component or the soldering. Use normal troubleshooting procedures to clear the problem before going to the next test.

If the display works, go to the next test. If the display does not work, do not go to the next step until the problem is corrected.

Test the Keyboard

Press the keys F1 to F4 in order.

Keyboard:
Successively press
F1-F4
F1 F2 F3 F4



The text F1 F2 F3 F4 appears on the screen as you press each key.

Shortly after F1 through F4 have been pressed the display should show:

Test okay...

If the keyboard test was successful, the next text appears:

RS-232:
Connect PC and
Press F1 if data
is readable

At this time, the SAM-III is transmitting on its serial port; however. DO NOT press F1 yet. The preliminary tests are done. Go to the next test.

Test the EIA-232 Serial Interface:

SAM-III Construction Manual

To test the EIA-232 serial port, it will be necessary to use a terminal emulator program such as HyperTerminal or Tera Term or PuTTY. Go to the next step to setup HyperTerminal.

Tera Term is available from <https://ttssh2.osdn.jp/index.html.en> and its setup is very similar to HyperTerminal; if in doubt use the online Tera Term manual or search online for setup procedures. For example, Tera Term serial port setup information may be found at <https://learn.sparkfun.com/tutorials/terminal-basics/tera-term-windows>

DO NOT connect the SAM-III serial port to the PC serial port or to a USB-serial adapter until instructed to do so.

Setup HyperTerminal

Start the HyperTerminal program (Start – All Programs – Accessories – Communications) and create a new connection. If you had a connection setup for a SAM-II, you may skip the setup and just open the connection.

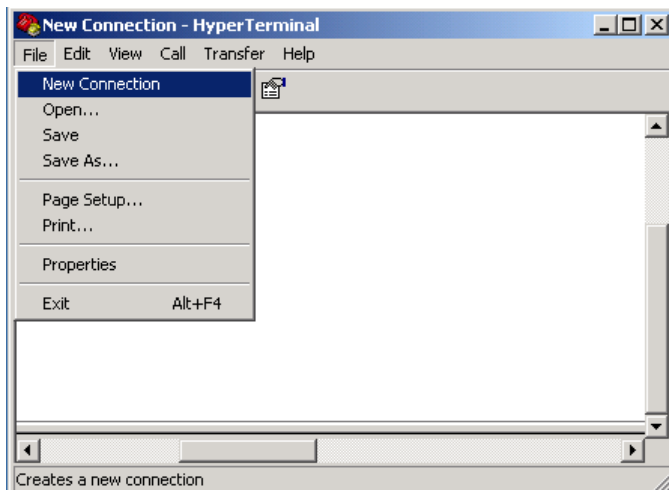

Select File – New Connection.

SAM-III Construction Manual

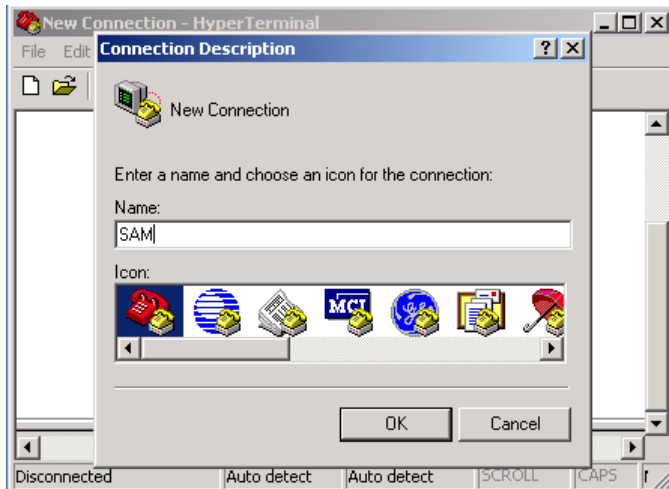

Type the name SAM.

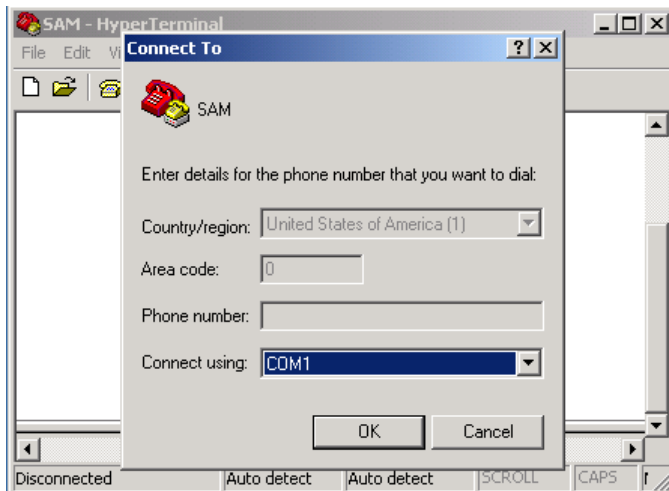

Choose the appropriate COM Port from the dropdown list. If you are using a USB-serial adapter, this is the COM Port used by the adapter. Plug the adapter into a USB port, but **DO NOT** connect it to the SAM-III serial port. Check that the latest USB-serial adapter drivers are installed (do that now) and upgrade the driver if necessary. **DO NOT** use the Windows driver update function in the serial port driver properties window. Download the drivers directly from the USB-serial adapter chipset manufacturer's website (usually Prolific or FTDI). **DO NOT** download the drivers from any location except the manufacturer's website. Additional USB-serial adapter information can be found at http://www.reeve.com/Documents/Articles%20Papers/Reeve_USBPortMgmtGuide.pdf

DO NOT connect the USB-serial adapter to a PC through a USB hub; connect the adapter directly to the PC. To find the COM Port assigned to the adapter, go to Start – Control Panel – System – Hardware Tab – Device Manager and click the + next to Ports (COM & LPT).

If you have other USB devices connected to your PC, unplug them (except, of course, your USB mouse and keyboard if you have them) to avoid port conflicts.

SAM-III Construction Manual

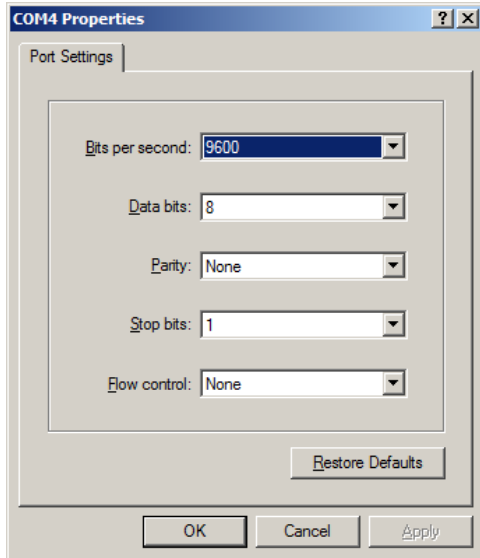

Adjust the settings in the drop-down boxes as follows: 9600 Bits per second – 8 Data bits – Parity None – Stop bits 1 – Flow control None. Click OK. If necessary, press the Call icon button on the HyperTerminal menu bar.

Now connect the USB-serial adapter to the SAM-III serial port.

The text "RS232-OK" should appear in the HyperTerminal window as shown below.

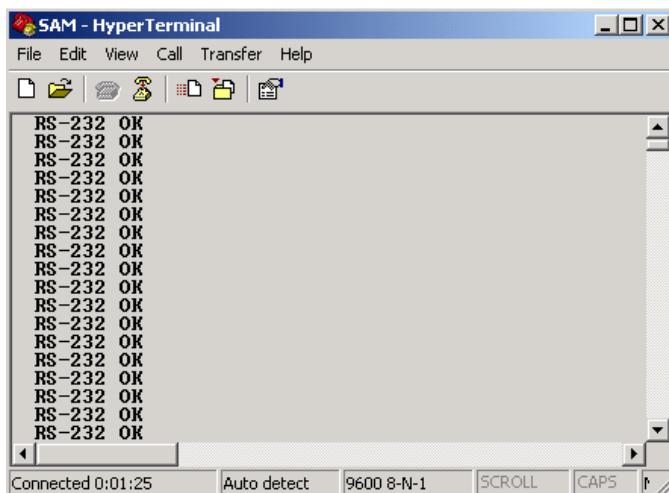

If nothing happens, try unplugging the USB connector of the USB-serial adapter and plugging it back into the PC. There is considerable variability in USB-serial adapters leading to many problems with serial port testing.

If the test message still does not appear, leave the serial port connections and HyperTerminal as they are and press the Reset pushbutton on the main PCB. After the processor has booted, press F1, F2, F3 and F4 in that order as in the *Test the Keyboard* section above. A moment after pressing F4, the SAM-III starts transmitting the test message and it should appear in the HyperTerminal window.

SAM-III Construction Manual

If you continue to have problems, it also is possible that pins 2 and 3 on JS1 need to be swapped. Use a digital multimeter set to the 20 Vdc voltage range to measure the voltages on the DB-9M connector.

Measure the voltage from

- pin 5 (negative multimeter lead) to pin 2 (positive multimeter lead)
- pin 5 (negative multimeter lead) to pin 3 (positive multimeter lead)

In both cases, the voltage should be in the range -6V to -12V . If not, remove power from the SAM-III and try swapping pins 2 and 3 on the DB-9M connector or the 3-pin header connector. A good software tool for troubleshooting serial ports is *PortMon for Windows*. It is free and available from <http://technet.microsoft.com/en-us/sysinternals/bb896644.aspx>.

If the terminal emulator program (HyperTerminal) is configured properly and the serial port is wired correctly, the HyperTerminal window should show a continuous stream of text "RS-232 OK". The SAM-III LCD shows

```
RS-232 :  
Connect PC and  
Press F1 if data  
is readable
```

When the serial port tests okay, press F1 and the following will flash on the LCD:

```
RS-232 :  
Test okay...
```

In HyperTerminal, press the DISCONNECT icon and close the program.

Go to the next test.

Test and Set the Real Time Clock

The real-time clock should be set to Universal Coordinated Time (UTC) so that it operates on the same time scale as other geomagnetometers throughout the world. In the United States, first go to <http://nist.time.gov/> to set your PC clock or watch, and then set the SAM-III time as described below. For other areas of the world, go to <http://www.timeanddate.com/worldclock/> to find your location and set your PC or watch.

Over the years, slightly different versions of the Initialization firmware have been used that limit the range of years that could be set. The version used as of 16 February 2021 allows the year to be set anywhere from 2020 to 2035. If you have the version of the Initialization firmware from 10 March 2011, the date range was 2002 to 2020. However, both versions of firmware roll over correctly into later years. For example, the 10 March 2011 firmware will correctly roll over to 2021 one minute after 23:59:00 on 31 December 2020.

When setting the SAM-III real time clock, the first line displays the Date and Time. The display format is DD.MM.YY HR:MM:SS. In operation, the SAM clock display format is HR.MM. The day, month, year, hour, and minutes can be set; the seconds cannot be set directly. In the procedures below, the field

SAM-III Construction Manual

being adjusted is highlighted in green. The highlight does not show on the LCD; however, by pressing the F2 and F3 keys, it will be obvious which field is changed.

After successfully completing the serial port tests, the LCD will look something like this

```
00.01.00 00:05:56
Clock:
Press F1 if clock
is running
```

If the clock is running, the seconds field (1st line, last field on right) will be counting. If it is counting, press F1. The display will flash

```
Test okay...
```

Now the day can be set

```
00.01.00 00:29:32
Set date: day
F1=OK
F2=+ F3=-
```

Use the F2 or F3 function keys to scroll the day field up or down. When set to the correct day, press F1.

The screen to set the month appears

```
25.01.00 00:29:49
Set date: month
F1=OK
F2=+ F3=-
```

Use the F2 or F3 function keys to scroll the month field. When set to the correct month, press F1.

The screen to set the year appears

```
25.07.00 00:30:02
Set date: year
F1=OK
F2=+ F3=-
```

Use the F2 or F3 function keys to scroll the year field. When set to the correct year, press F1.

The screen to set the hour appears

```
25.07.09 00:31:10
Set time: hour
F1=OK
F2=+ F3=-
```

SAM-III Construction Manual

Use the F2 or F3 function keys to scroll the hour field. Set the hour to UTC so that your magnetograms use the same time scale as other geomagnetometers. When set to the correct hour, press F1.

The screen to set the minute appears

```
25.07.09 00:31:21
Set time: minute
F1=OK
F2=+ F3=-
```

Use the F2 or F3 function keys to scroll the minute field. When set to the correct minute, press F1. Note that the seconds cannot be set, but the seconds are reset to zero each time you scroll the minute field. With a little practice, you can set the minutes and seconds exactly to correspond to your watch or PC clock. The clock is now adjusted. It will keep time with power removed from the SAM-III controller PCB (the real time clock IC is battery powered by G1). However, if you ever remove the JP2 header shorting block with no power on the SAM-III, the clock will have to be reset. This can be done when the SAM is in operation as described in the Software Setup Guide.

Go to the next test.

Test Inputs and Outputs

The SAM-III input and outputs appear on the 8-position pluggable terminal block X1. The wiring of the terminal block is shown below.

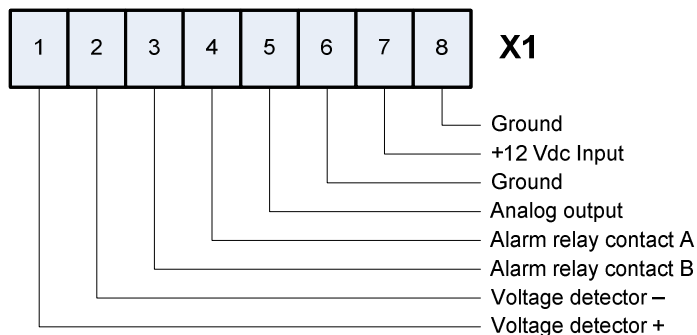

Test the Alarm Relay

After the clock has been adjusted, the following text should show on the LCD:

```
Alarm switch:
Relay switches in
1s-interval. Press
F1 to confirm.
```

Note: Early versions have a spelling error on the display (Relais switches in). The relay switches every few seconds. You may be able to hear the clicking if you put your ear near the board. If you do not hear anything, set a digital multimeter to measure resistance and connect one lead to position 3 of X1 and the other to position 4.

SAM-III Construction Manual

The measured resistance should alternate between an open and short circuit. Note: Some digital multimeters do not respond fast enough to provide a meaningful display, but the display should not show a steady open (infinite resistance) or steady short (zero resistance). A low-inertia (small and light) analog ohmmeter is best for this test but a digital multimeter can be used.

Press F1 if the test is successful and to move to the next test.

Test the Input

The input circuit is decoupled from the rest of the circuits by an opto-coupler (opto-isolator). An external 12 V dc voltage source is required for this test. When F1 was pressed in the previous test, the LCD should show

```
Digital input:  
Apply voltage to  
digital input.  
Press F1 to abort.
```

The digital input test can be skipped by pressing F1. If you press F1, you should see

```
Digital input:  
Test aborted
```

If the test is aborted, the SAM-III automatically will go to the next test.

To proceed with the test, refer to the X1 terminal block pinout shown above. Connect the + lead from an isolated 12 Vdc power supply to pin 1 of X1 and the – lead to Pin 2. Note: 12 V dc is available between pin 7 (+) and pin 8 (–) of X1. It may be used to test the input but this voltage is not isolated from the PCB ground, and it will not be a true test of the isolated input circuit.

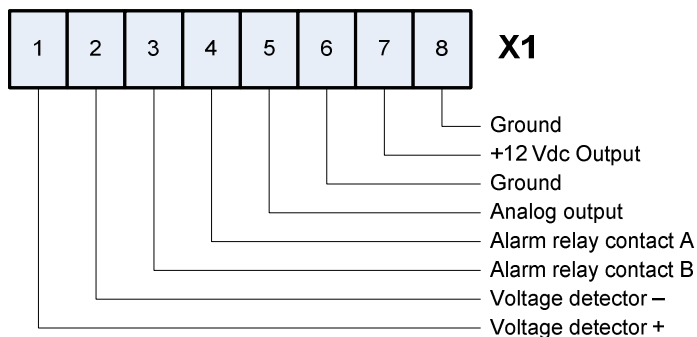

As soon as the SAM-III processor detects 12 V the following text will appear on the display:

```
Digital input:  
Test ok...
```

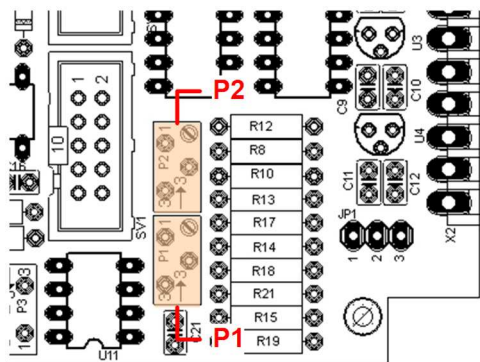

The SAM-III automatically will go to the next test.

Test and Adjust the Analog Output

The SAM-III has one analog output channel that provides a voltage proportional to the K-Index computed by the SAM-III sensor. The analog output is adjusted by potentiometers P1 and P2. The locations of P1 and P2 are shown below.

SAM-III Construction Manual

The output can be calibrated to provide a range of 0 to +5 V or -2.5 to +2.5 V. The SAM-III analog output is proportional to K-index, so it is recommended that it be calibrated for a range of 0 to +5 V. If you do not plan to use the analog output, this step can be skipped.

After the previous tests were done, the SAM-III displays the following text:

```
analog output
P1: gain P2: offset
F1 = OK F2 = 1/2Umax
F3 = Umax F4 = Umin
```

To set the output to a range of 0 to 5 V, press F3 (Umax)

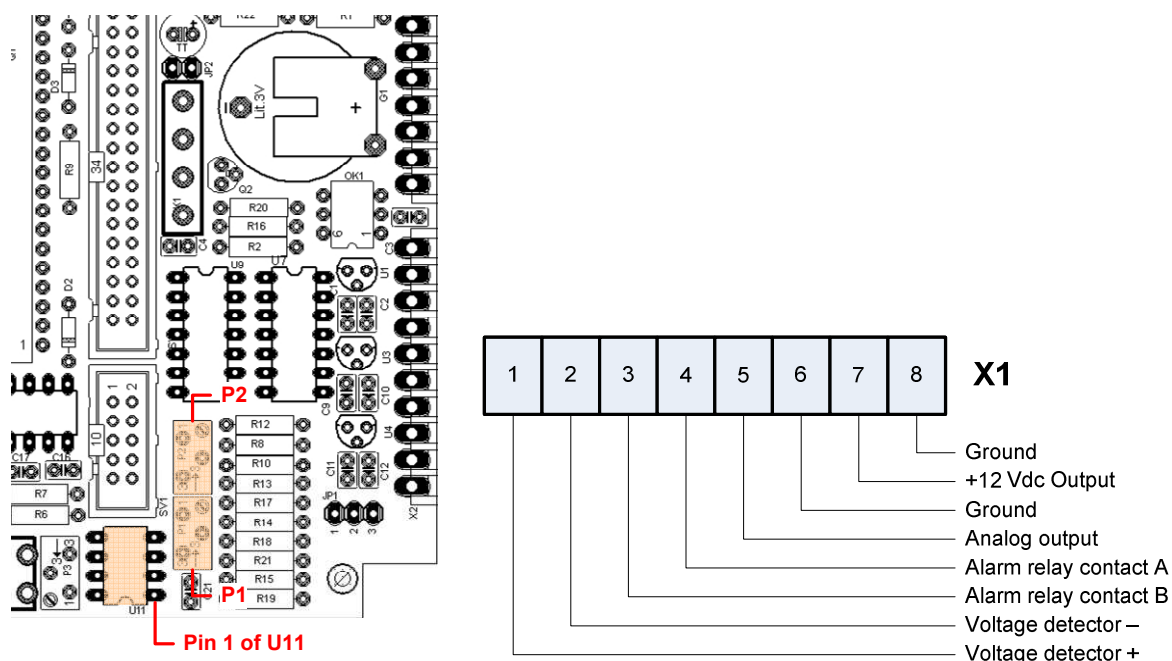

Set the multimeter to the 20 Vdc range, and connect the meter negative lead to position 6 (ground) of X1.

A. Press F3 (Umax). Connect the meter positive lead to pin 1 of U11 (LM358N op-amp). See illustration above. Adjust P1 until the meter reads +5.00 V.

B. Press F4 (Umin). Connect the meter positive lead to position 5 of X1 (analog output). Adjust P2 until the meter reads 0.00 V.

C. Press F3 (Umax). Adjust P1 until the meter reads 5.00 V. Repeat B. and C. adjustments until the voltages do not change.

For a range of -2.5 V to +2.5 V, press F2 (1/2Umax).

Connect the meter negative lead to position 6 (ground) of X1. Connect the meter positive lead to pin 5 of X1. Adjust P2 until the meter shows 0.00 V. Repeat the previous adjustments until the voltages do not change.

SAM-III Construction Manual

Press F1 when you are done adjusting the analog output channel. The following will briefly flash on the LCD:

```
Test completed
```

The LCD will then show

```
Initialize EEPROM  
with default parame-  
ters?  
F1 = yes F2 = no
```

All tests are now done!

The above tests and adjustment can be repeated by pressing the reset button on the SAM-III controller PCB. You have to cycle through the entire set of tests but you can skip a particular test or adjustment by pressing F1. You can press the reset button any time and it will not change anything.

If you are finished with testing and adjusting, you can initialize the SAM-III EEPROM with default parameters by pressing F1 when you see the displayed text above. The default parameters include basic parameters for a single sensor, K-index values, alarm threshold and so on. These are values that SAM-III will use upon power-up or reset. The default parameters can be changed later. If you press F1, the LCD should briefly show

```
EEPROM initialized  
successfully.
```

The LCD should then show

```
Congratulations! SAM  
is ready for opera-  
tion. Load SAM.HEX  
now...
```

You are ready to load the operating system software onto the SAM-III microprocessor as described in the next section. Nothing will be harmed if you remove power from the SAM-III.

If you pressed F2 instead of F1, the EEPROM will not be initialized with default parameters, but it otherwise will be ready for installation of the operating system software. When you press F2, the LCD should briefly show

```
EEPROM not  
initialized.
```

The LCD should then show

```
Congratulations! SAM  
is ready for opera-
```

SAM-III Construction Manual

tion. Load SAM.HEX
now...

If you just finished construction of the SAM-III PCBs, you normally would press F1 to load the default parameters. On the other hand, you would press F2 if you had been using the SAM-III for some time and wanted to readjust the analog output or retest a function but wanted to retain the parameter settings from previous use. In this case, you would load the initialization and test software (IB3_ENG.HEX), make the adjustments and tests, but press F2 at the end. Whatever parameters were in EEPROM will be retained.

Trouble Shooting

If problems occur during testing, double-check the following:

Current drawn by the SAM. With no sensors connected the current draw is approximately 30 mA with the LCD backlight off and 50 mA with the backlight on. Each sensor adds about 5-10 mA to the load current

Resistors are correct values and in their correct locations

Diodes correctly oriented and in their correct locations

Capacitors in their correct locations and electrolytic capacitors oriented correctly

ICs soldered properly and oriented correctly

No cold solder joints

All pins soldered

No solder bridges or shorts

Power supply input voltage and the voltage at the voltage regulator outputs

If no problems are found but the SAM-III still does not test okay, contact us by email (SAMinfo@reeve.com).

SAM-III Construction Manual

XII. Load the Microprocessor Operating System Firmware

The supplied microprocessor has bootloader and test/initialization firmware (IB3_ENG_DDMMYYYY.HEX) preloaded. The test/initialization firmware is used only for testing purposes as described in the previous section. It is now necessary to replace the test/initialization firmware with the operating system firmware (SAM3_ENG_xxxx.HEX) so that the SAM can be used with the application programs (the applications programs are described in the SAM Software Setup Guide).

Note that either IB3_ENG.HEX or SAM3_ENG.EXE can be loaded onto the microprocessor but not both at the same time. In general, IB3_ENG.HEX is loaded when it is necessary to test and adjust the SAM-III, and SAM3_ENG.EXE is loaded when the SAM-III is to be placed in service.

The operating system program is loaded through the EIA-232 serial port from a Windows PC running a PIC loader program. The PIC loader supplied on the SAM CD is freeware called *PIC_downloader.exe* and it is compatible with the bootloader firmware already installed on the PIC. Remember this loader only supports COM1 through COM6. If you have a USB-serial interface adapter, it must be configured for one of these ports.

Caution: Not all USB-Serial Adapters are the same. Some adapters may work fine on the serial port test in Sect. XI but will not work with PIC_downloader. It has been found that at least one adapter performs so poorly that it will corrupt the microprocessor (U10) firmware including the bootloader. If the bootloader is corrupted the microprocessor becomes useless and can be recovered only with a PIC programmer. If you do not have a PIC programmer, a new microprocessor will have to be sent to you (US\$20 + shipping charge for a replacement microprocessor). Generally, the cheaper the adapter, the more problems you will have with it.

The following USB-Serial adapters are known to work with SAM-III on Window XP and Windows 7:

- StarTech USB-Serial Converters (later models compatible with Windows 7)
- TRENDnet TU-S9 version 2 (white)
- Plugable USB Serial Converter

The following USB-Serial adapter is known to NOT work:

- Bright blue adapter marked HL-340

Many adapters that work on XP and 7 do not work on Windows 10. This is both a chip and driver problem, and you probably will need to purchase a new adapter. See

http://www.reeve.com/Documents/Articles%20Papers/Reeve_USBPortMgmtGuide.pdf

SAM-III Construction Manual

To load the operating system software

1. Create a new folder such as C:\SAM\PICLoader
2. Unzip the picloader.zip file into the new folder
3. Run PIC_downloader.exe
4. Set the parameters as follows:
 - File: SAM3_ENG.EXE or SAM3T_ENG.HEX [use SEARCH (F2) to find the file]; see note
 - Port: Set to the PC serial COM Port that is connected to the SAM
 - Speed: 19200 Bd
 - EEPROM [DO NOT check]

Note: If you plan to use the external temperature sensor (Sect. XVII), you should load SAM3T_ENG.HEX at this time. Even if you do not plan to use the temperature sensor, there is no harm in loading this firmware. The application program (SAM_VIEW) will automatically detect whether or not temperature data is in the SAM-III data stream. If you load SAM3_ENG.HEX and later decide to use the temperature sensor, you can easily replace it with SAM3T_ENG.HEX at that time.

When all parameters are set (refer to the screenshot below), press F4 – Write. The PIC downloader should show “Searching for bootloader” and look something like this (the Filename will be as above):

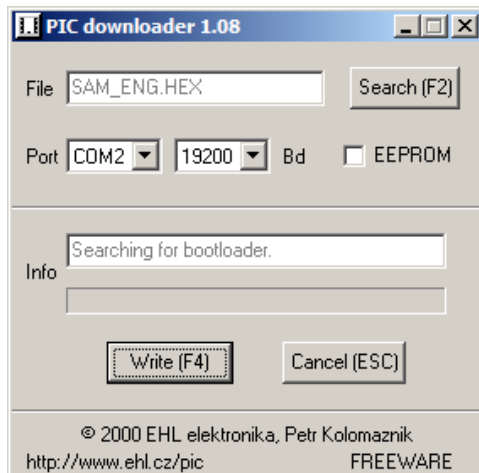

Press the reset button on the SAM-III controller PCB. The PIC downloader should immediately start writing the file as shown below. If there is no response, momentarily disconnect the power from the SAM-III to force a hard reboot. The PIC downloader should starting writing.

SAM-III Construction Manual

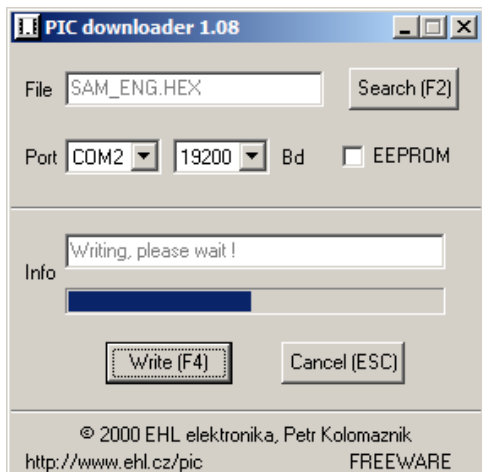

When done, the PIC downloader should look like this, and the SAM-III should automatically reboot.

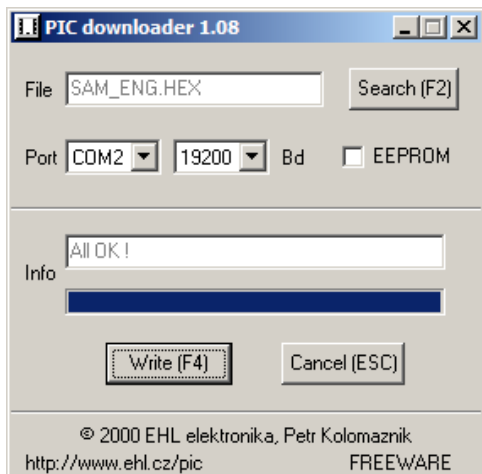

If the sequence does not complete properly, see Troubleshooting PIC downloader below.

After the SAM-III has rebooted, press the RESET (F3) button on the SAM-III keyboard. The SAM-III should reset and the LCD should look like this (line 4 initially will be blank but will appear after a moment)

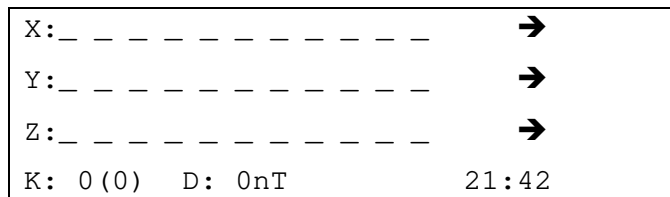

The display indicates blank magnetic induction values. Actual values will not be displayed until sensors are connected. The next section describes the display layout for reference purposes.

If you run HyperTerminal and connect to the SAM-III serial port, you should see data being transmitted. Since no sensors are connected, the magnetic induction fields will be blank, but the data should look like this. The first six fields are the date and time followed by X, Y and Z:

SAM-III Construction Manual

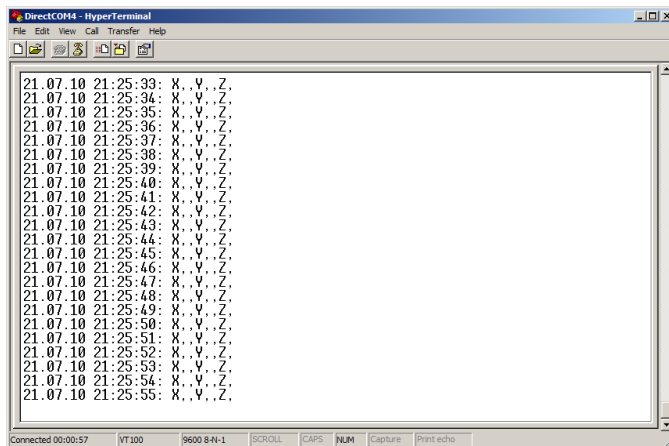

The ***SAM Software Setup Guide*** describes how to install and use the application software.

At this point, you can install the PCBs in an enclosure as described in the section following the display layout and keyboard description. The section following the enclosure installation describes how to hook up and install the sensor.

Troubleshooting the Serial Port:

If you encounter these dialog boxes when using PIC downloader,

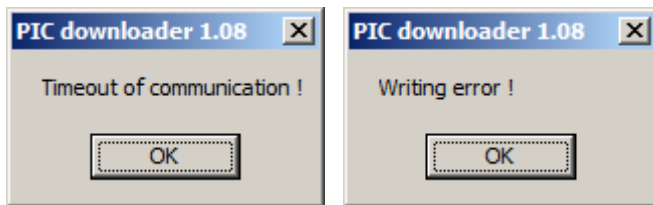

there was a communication problem with the serial port. Sometimes this can be resolved by unplugging and then plugging the USB connector on the USB-serial adapter. If that does not work, use PortMon to analyze the serial connection (see appendix). See also oscilloscope screenshots below as a troubleshooting aid if you have an oscilloscope.

Oscilloscope:

PC → SAM-III, measured at Pin 2 of JP1 while waiting to press RESET to download IB3_ENG.HEX from PIC downloader: Image F0000TEK

SAM-III Construction Manual

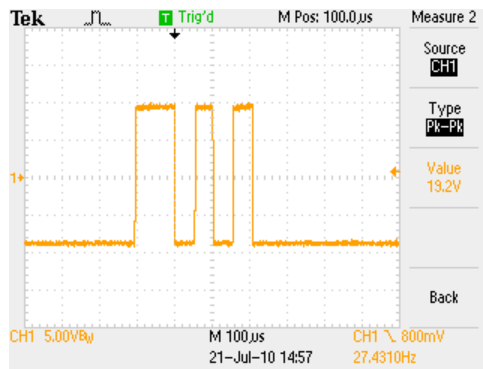

SAM-III → PC, measured at Pin 3 of JP1 while waiting to press RESET to download IB3_ENG.HEX:
Approximately -7 Vdc

PC → SAM-III, measured at Pin 2 of JP1 after pressing RESET and while receiving IB3_ENG.HEX from PIC
downloader: Image F0001TEK

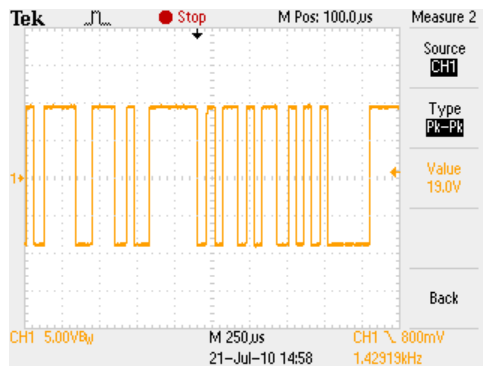

PC → SAM-III, measured at Pin 2 of JP1 after pressing RESET and while receiving IB3_ENG.HEX from PIC
downloader: Image F0002TEK (different timebase than F0001TEK)

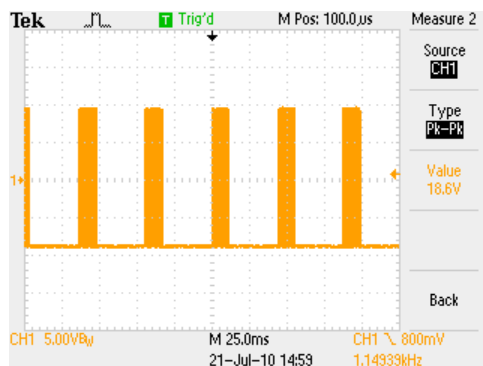

SAM-III → PC, measured at Pin 3 of JP1 after pressing RESET and while downloading IB3_ENG.HEX from
PIC downloader: Image F0003TEK

SAM-III Construction Manual

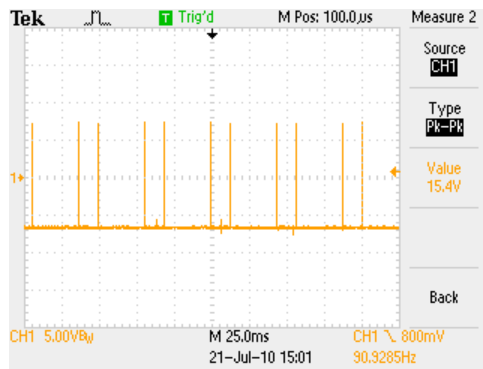

SAM-III \rightarrow PC, measured at Pin 3 of JP1 while downloading IB3_ENG.HEX from PIC downloader: Image F0004TEK (different timebase than F0003TEK)

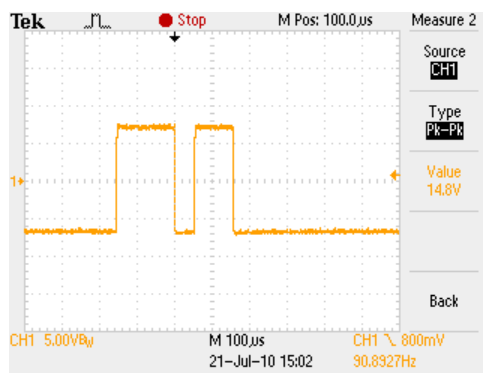

SAM-III \rightarrow PC, measured at Pin 3 of JP1 while sending "RS232" text to HyperTerminal: Image F0005TEK

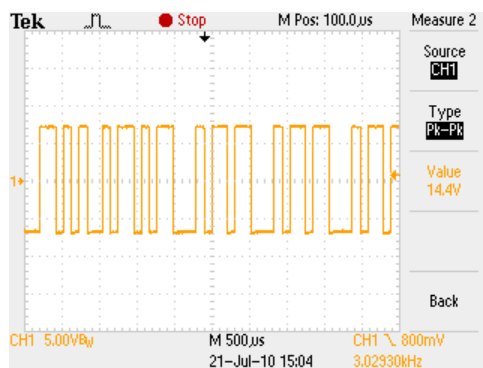

PC \rightarrow SAM-III, measured at Pin 2 of JP1 while sending "RS232" text to HyperTerminal: Approximately -9 Vdc

PC \rightarrow SAM-III, measured at Pin 2 of JP1 while waiting to press RESET to download SAM3_ENG.HEX from PIC downloader: Image F0006TEK

SAM-III Construction Manual

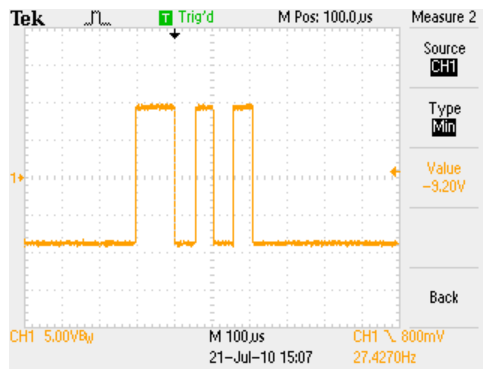

SAM-III \rightarrow PC, measured at Pin 3 of JP1 while waiting to press RESET to download SAM3_ENG.HEX:
Approximately -7 Vdc

PC \rightarrow SAM-III, measured at Pin 2 of JP1 while receiving SAM3_ENG.HEX in progress from PIC
downloader: Image F0007TEK

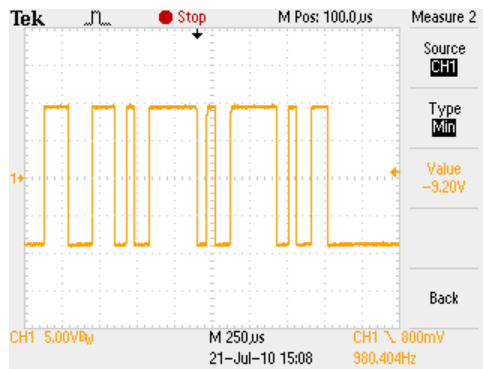

SAM-III \rightarrow PC, measured at Pin 3 of JP1 while sending sensor data text to HyperTerminal: Image
F0008TEK

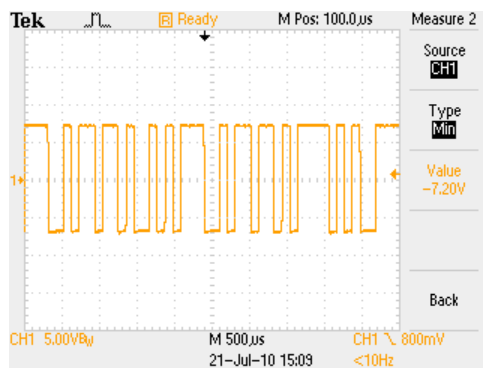

SAM-III \rightarrow PC, measured at Pin 3 of JP1 while sending sensor data text to HyperTerminal: Image
F0009TEK (different timebase than F0008TEK)

SAM-III Construction Manual

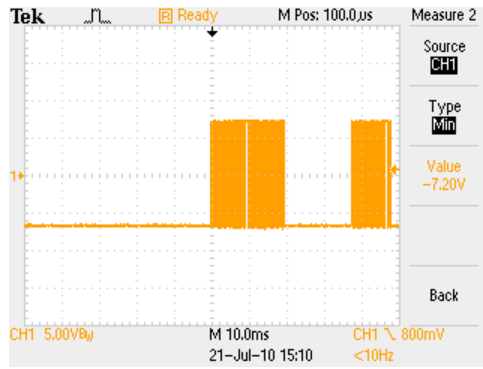

SAM-III Construction Manual

XIII. SAM-III Display and Keyboard Reference Information

SAM Display:

The SAM-III display is a 4x20 (4 lines x 20 characters per line) LCD with the following layout:

Line	Example
1	X: _____ →
2	Y: _____ →
3	Z: _____ →
4	K: 4 (5) D: 61nT 21:42

Line 1, 2 & 3: Measured value of magnetic induction in nT for axis Indicated / Relative value compared to the value at 00:00 UTC or first value after reset/power on and Trend indicator.

The Trend indicator shows the trend of the magnetic field over the last 20 minutes. It also is used to trigger the K-Index alarm relay (relay K1, contacts on X1 positions 3 and 4). The SAM-III calculates the variations over the last 20 minutes and compares the amplitude of the variations with the K-Index triggers. If the variation is such that K-Index value K4 would be reached within 20 minutes, the alarm is triggered.

The trend indicator symbols are:

Quiet magnetic field: “->” (20 minute variation \leq K2)

Moderate field variations: “/” or “\” for falling or rising (20 minute variations \leq K4)

Strong variations: “|” – ALARM (20 minute variations $>$ K4)

If an alarm is triggered, it will reset after 20 minutes unless the condition that caused the alarm continues to be in effect.

Line 4:

Normal operation: Current period K-index (previous period K-index) and magnetic field variation within the current K-index period. The K-indices are determined for the prescribed three hourly intervals (0000-0300, 0300-0600, . . . , 2100-2400). The K-index displayed first is measured from the beginning of the current 3-hour period with K0 assigned at the beginning of the interval. The K-index displayed in parentheses is for the previous 3-hour period. In the example shown, the current K-index is K4 as measured from the beginning of the current 3-hour period (1200), the K-index was K5 at the end of the previous K-index interval (1200), and the current amplitude variation is 61 nT.

The maximum positive and negative deviations during the 3-hour period are added together to determine the total maximum fluctuation. These maximum deviations may occur anytime during the 3-hour period.

SAM-III Construction Manual

The K-index varies by location (latitude and longitude). The default values are typical for approximately 40-50 deg. north latitude. The actual K-index limits for a given location normally are determined over a period of time, typically at least one year corresponding to one solar cycle. Professional geomagnetometer systems typically go through a 22 year (complete positive and negative sunspot cycles) calibration period. For SAM-III purposes, starting values may be obtained from a nearby magnetic field observatory. For additional information on the K-index and how to set it for your installation, refer to *Geomagnetism Tutorial* available from the following web address:

<http://www.reeve.com/Documents/SAM/GeomagnetismTutorial.pdf>

The K-index triggers can be changed in the SAM-III processor for standalone mode by using the SAM_INI version 2.0 program. The charting program, SAM_VIEW, also has its own triggers for computing the K-index so the values have to be set twice - in the microprocessor EEPROM for standalone operation using SAM3_INI and again in SAM_VIEW for logging operation with a PC. See the SAM-III Software Setup Guide for details on using SAM3_INI and SAM_VIEW.

Time HR:MM.

The time field is self-explanatory.

Calibration mode: When a sensor is connected and function key F2 is pressed, the LCD changes to show the measured magnetic induction value and sensor frequency. Each sensor, X, Y and Z, will be shown. If no sensor is installed for a particular axis, the magnetic induction and frequency shown on the display for that axis will be -82000nT and 0Hz as in the example below for the X-axis. The time will be shown in the lower-right corner of the display. Press F2 again to exit sensor Calibration mode.

X: -82000 / _____0Hz	No sensor installed
Y: 24324nT/46847Hz	Sensor installed
Z: 8013nT/55547Hz	Sensor installed

SAM-III Keyboard:

With the SAM3_ENG.HEX operating system installed, the SAM-III keyboard function keys F1 – F4 operate as follows:

- F1:** Command Mode (places the SAM-III in command mode for uploading or downloading setup information, LED flashes at ~2 Hz rate)
- F2:** Calibration Mode (displays the sensor counter frequency, LED flashes at ~2 Hz rate)
- F3:** Software Reset (restarts the SAM-III microprocessor but retains EEPROM parameters)
- F4:** Display Backlight (Turns on the backlight)

SAM-III Construction Manual

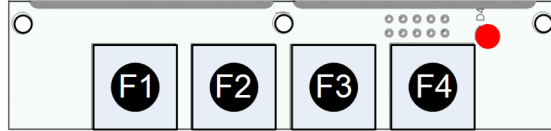

SAM-III Construction Manual

XIV. Install the Controller, Keyboard and LCD in the Enclosure

If an optional enclosure is to be used, the three printed circuit boards should be installed now. Two types of enclosures have been supplied as options with the SAM-III, a plastic sloped enclosure, p/n EC-1, covered in this section, and a plastic rectangular enclosure, p/n BEN-1, covered in a separate document. Refer to the documents section of the CD or USB drive supplied with the SAM-III kit for instructions on the BEN-1 enclosure.

EC-1 Enclosure: The builder is required to use a certain amount of resourcefulness and planning to install the boards in the optional enclosure.

The optional enclosure is a slightly sloped and consists of several parts as shown below.

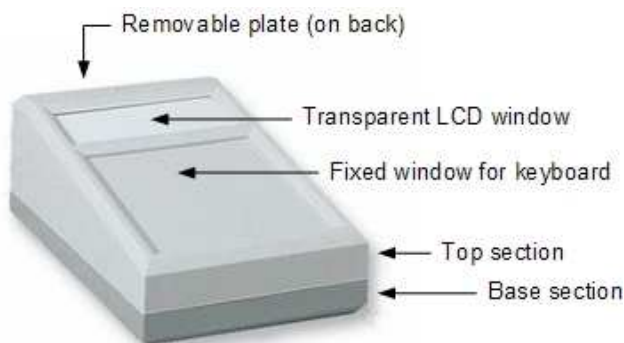

If you purchased the optional EC-1 enclosure, the following items are included:

Parts list ID	Qty	Description
<input type="checkbox"/>	1	Enclosure with LCD cutout
		LCD mounting hardware consisting of
<input type="checkbox"/>	4	#4 x 3/16 in. plastic spacer
<input type="checkbox"/>	4	#3 x 1/2 in. self-threading screw
<input type="checkbox"/>	4	#4 x 1/2 in. self-threading screw
		Keyboard PCB mounting hardware consisting of
<input type="checkbox"/>	2	#4 x 0.062 in. nylon washer
<input type="checkbox"/>	2	#3 x 1/2 in. self-threading screw
<input type="checkbox"/>	2	#4 x 1/2 in. self-threading screw
		Controller PCB mounting hardware consisting of
<input type="checkbox"/>	1	4-40 x 3/8 in. nylon hex standoff
<input type="checkbox"/>	1	4-40 nylon hex nut
<input type="checkbox"/>	1	4-40 x 5/16 in. pan-head screw
<input type="checkbox"/>	2	#4 x 1/2 in. self-threading screw
<input type="checkbox"/>	3	#4 x 0.062 in. nylon washer
<input type="checkbox"/>	2	#4 x 3/16 in. plastic spacer
		Serial port connector mounting hardware consisting of
<input type="checkbox"/>	2	4-40 hex jackscrew
<input type="checkbox"/>	2	4-40 hex nut

SAM-III Construction Manual

- 2 #4 lock washer

It will be necessary to cut holes for the pluggable terminal blocks, serial port connector, dc coaxial power jack, keyboard pushbuttons and keyboard LED. The enclosure top section has molded screw landings already installed for mounting the LCD and keyboard, but additional spacers are required (spacers are supplied with the optional enclosure). When viewing the enclosure from the front, the open window for the LCD is at the top. The keyboard is mounted on the fixed window section just below the display.

Before cutting any holes, double-check the dimensions shown on the drawings to make sure they correspond to your parts. There will be some minor variations because of manufacturing and shop tolerances and substitutions. The datasheets for some components are in mm and for other components are in inches. Dimensions have been retained in the drawings.

The drawings in this section are not to scale but images are provided on the supplied CD. You can adjust the image scales as necessary using any drawing program such as Microsoft Paint.

Always start with a small drill to cut a pilot hole, 1/16 in. – 3/32 in. (1.5 mm – 2.4 mm) diameter, make a test fit and then enlarge the hole as required. The plastic material is soft plastic and easy to cut. Brad-point drills and step drills work well.

Controller PCB:

The controller PCB is mounted in the base section with the pluggable terminal blocks facing the back (away from you as you look at the enclosure). The controller PCB requires two spacers, one standoff and three thick nylon washers as shown in the drawings below.

The standoff is 3/8 in. long nylon hex standoff with a 4-40 threaded stud at one end. The stud is inserted through the hole in the PCB and a nylon 4-40 hex nut is screwed on. Carefully tighten the nut, but do not tighten it beyond snug or you will break the stud. The hex standoff is held to the base section by a 4-40 x 5/16 in. machine screw. Do not over tighten this screw. Use regular steel #4 self-threading hardware and two 3/16 in. spacers with thick washers to hold the PCB at the end with the pluggable terminal blocks.

The standoff and spacers supplied with the optional enclosure raise it about even with the edge of the base section. The PCB should be centered left-right in the base with the back edge (the edge with pluggable terminal blocks) flush with the base flange.

Controller PCB, viewed from top (component side); NOT full size. The controller PCB is mounted to the base section (see next drawing)

SAM-III Construction Manual

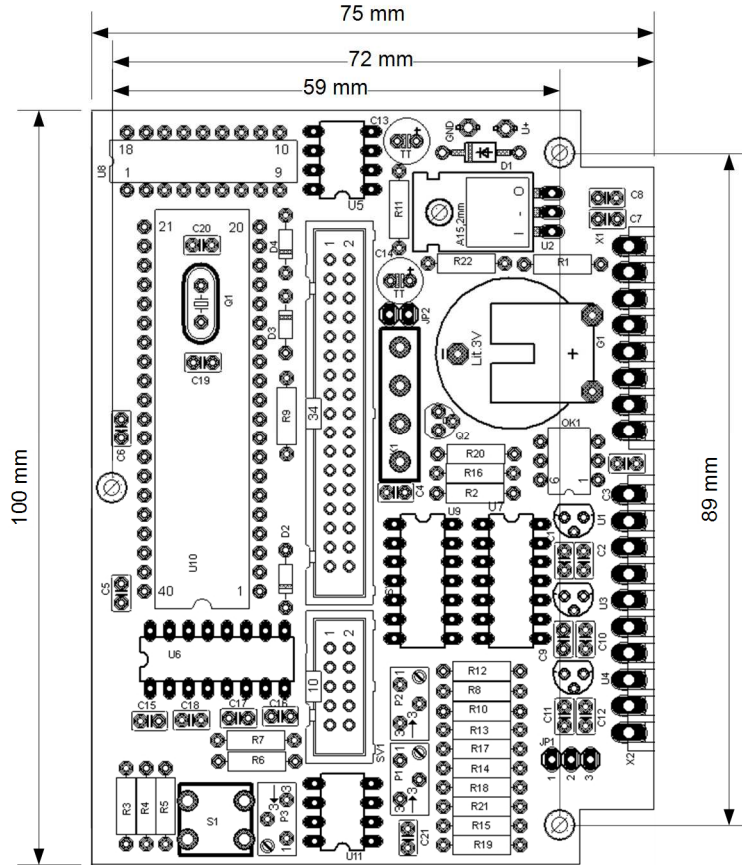

Base Section

- (1) 4-40 x 3/8 in. nylon hex standoff, M-F
- (1) #4 thick nylon washer
- (1) 4-40 x 5/16 in. pan-head screw
- (1) 4-40 nylon hex nut

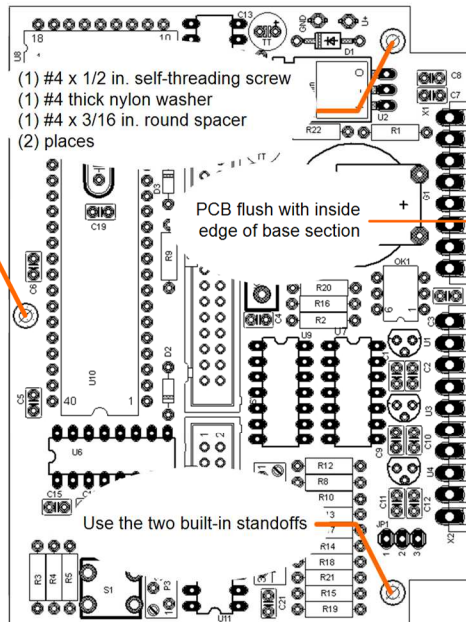

SAM-III Construction Manual

Backplate:

The openings in the removable back-plate for the pluggable terminal blocks, dc power connector and DB-9 serial port connector are shown in the drawing below. Cut the odd shape of the serial port connector by cutting two 3/8 in. holes and then trimming with a sharp hobby knife to an oblong shape. Mount the serial port connector with 4-40 hex jackscrew hardware (supplied with optional enclosure).

Rear of enclosure with removable back-plate, viewed from outside; NOT full size. Dimensions shown are approximate and should be verified before cutting holes

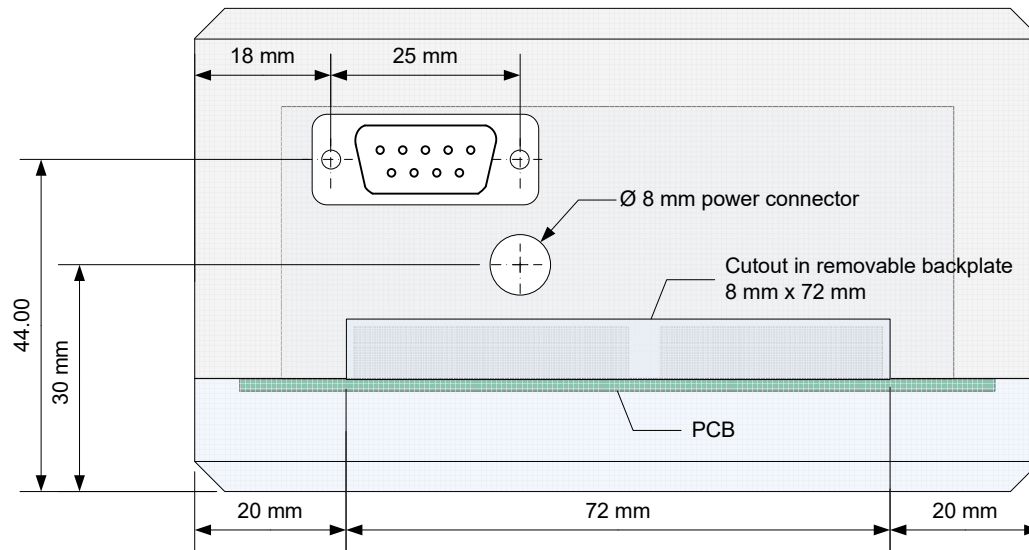

Keyboard:

The enclosure top section has two built-in molded standoffs for the keyboard just below the display window on the inside. These line up with the two outer holes in the keyboard PCB and provide sufficient support for most applications. If additional support is needed, use a spacer (not supplied) at the middle hole in the keyboard.

SAM-III Construction Manual

Before mounting the keyboard, cut the holes for the switches and LED. Pre-thread the standoffs with the supplied #3 x 1/2 in. screws; turn very slowly so you do not split the openings and only screw in part way so you do not penetrate the enclosure. Test fit the keyboard to make sure there is clearance and a good fit. Cut off about 1/8 in. (3.5 mm) from the screws and mount the keyboard using two #4 x 1/8 in. spacers. Carefully and slowly tighten the screws.

Keyboard area; NOT full size. The keyboard is mounted in the top section fixed window area below the display cutout. The drawing below is viewed from outside of the enclosure. Use a step drill or brad-point drill to cut the larger holes after pilot drilling. Not shown are the two mounting holes at the ends of the keyboard, which correspond to the molded standoffs in the enclosure top section. If these are the only mounting holes used, you do not need to drill the 3.5 mm hole in the middle. The dimensions shown below are nominal and should be verified before cutting holes. The position of the pushbuttons on the PCB may vary slightly.

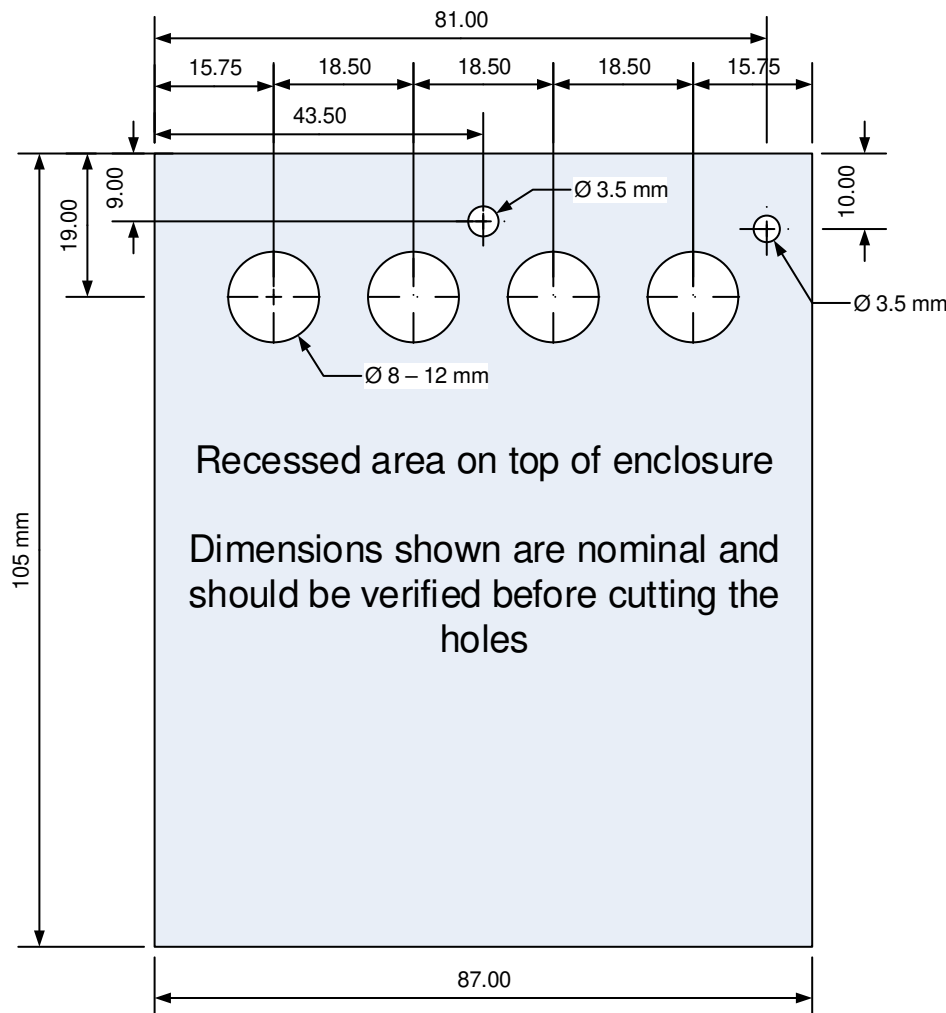

SAM-III Construction Manual

Display:

The LCD is installed on the built-in molded standoffs in the enclosure top section. Use the supplied 3/16 in. spacers and No. 3 or 4 x 1/2 in. self-threading screws. Before mounting the LCD, pre-thread the standoffs with the supplied screws; turn very slowly so you do not split the openings.

Before mounting the LCD, remove the protective film cover from the glass display. Also, peel the protective cover from the transparent window supplied with the enclosure and snap it into position in the window opening.

A keyboard label image is provided on the supplied CD. Print it and trim the holes with a sharp hobby knife.

Not full size. Keyboard label for use with the SAM



SAM-III Construction Manual

XV. Magnetometer Sensor Hookup

Read this entire section before connecting the magnetometer sensors to the SAM-III

Description

The sensors are manufactured for the SAM-III by Speake & Co Llanfapley. Up to three sensors can be used (see picture below). The sensors have four pins and the label on the sensor indicates pin designations. Note that the sensors are potted into a plastic tube. Some shrinkage may take place during the curing operation or from temperature cycling, creating what appears to be an air bubble under the clear plastic tube. This is cosmetic and does not affect sensor operation or performance.



Required parts for each equipped sensor:

Parts list ID	Qty	Description
<input type="checkbox"/>	1	Magnetometer sensor
<input type="checkbox"/>	1	4-pin header connector
<input type="checkbox"/>	4	Contact for header connector (3 required, 1 spare)
<input type="checkbox"/>	1	10 μ F, 25 V tantalum capacitor
<input type="checkbox"/>	1	100 nF, 25 V multi-layer ceramic capacitor
<input type="checkbox"/>	1	Sensor cable (not supplied)
<input type="checkbox"/>	1	Sensor enclosure (not supplied)

Sensor connections

SAM-III Construction Manual

Controller: The sensors connect to the SAM-III controller through the 10-position pluggable terminal block X2. The builder must supply the cable (discussed later in this section). The illustration below shows the pluggable connector pinout for connecting the three magnetometer sensors (X-, Y-and Z-components) and optional temperature sensor.

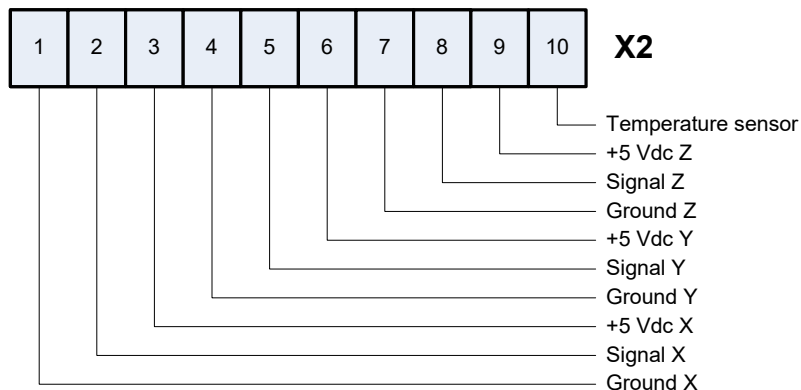

Magnetometer sensor: A 4-pin single inline header connector and contacts are supplied for connecting a user-supplied cable to each sensor. Crimp (if the proper tool is available) or solder the sensor cable wires to the contacts and insert them in the SIL header connector. The SIL header connector has slots on one side, and the tiny tabs on the contacts must be inserted on this side. Do not solder wires directly to the sensor. The sensor pinout is indicated on the sensor label and in the drawings below.

The socket contacts require a double-crimp, one for the conductor and one for the insulation. If you do not have a crimping tool and must solder the wires, it is suggested you cut the insulation crimp fingers off of the contact (otherwise, it is unlikely you can fold the fingers enough to make them fit the header connector). You will need to fold the conductor crimp with a pair of miniature pliers. Do this very carefully to avoid damaging the contact. Apply a very small amount of solder – if you apply too much solder it will wick up into the socket.

Before inserting the single inline (SIL) header onto the sensor pins, put a small amount of dielectric grease (for example, Permatex 81150 available at most automotive parts stores) on the sensor pins. The amount of grease used should be small enough that it is not visible on the pins. This will help prevent corrosion if the sensor is used in outdoor applications. The header has no built-in polarity indicator so it should be marked with nail polish, paint or tape to indicate proper orientation.

One, two or three sensors can be connected to the SAM-III. The schematic diagram below shows three sensors. This drawing assumes the 78L05 voltage regulators U1, U3 and U4 are installed on the controller PCB and the sensors are fed with 5 V power from the controller. If only one or two sensors are installed, they are connected to the appropriate axis on the SAM-III PCB. Two filter capacitors are used for each sensor, a fairly large value tantalum type for low frequency filtering and a small value ceramic type for high frequency filtering. Be sure to observe the polarity of the tantalum capacitor. A more detailed functional wiring diagram is provided below for a 2-sensor installation. It can be easily extended for three sensors.

SAM-III Construction Manual

Note: Crosstalk interference is likely when two or more sensors use the same cable. This is discussed later under Mutual Interference.

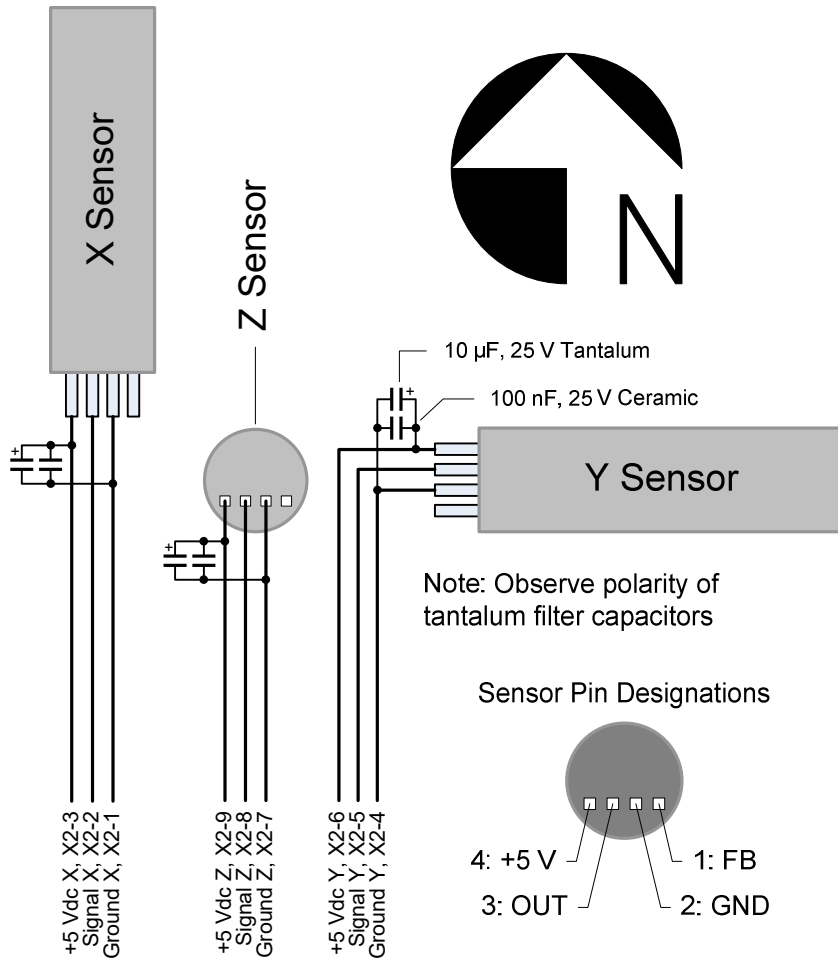

SAM-III Construction Manual

SAM Sensor Wiring Diagram Example (Note 1, 2)

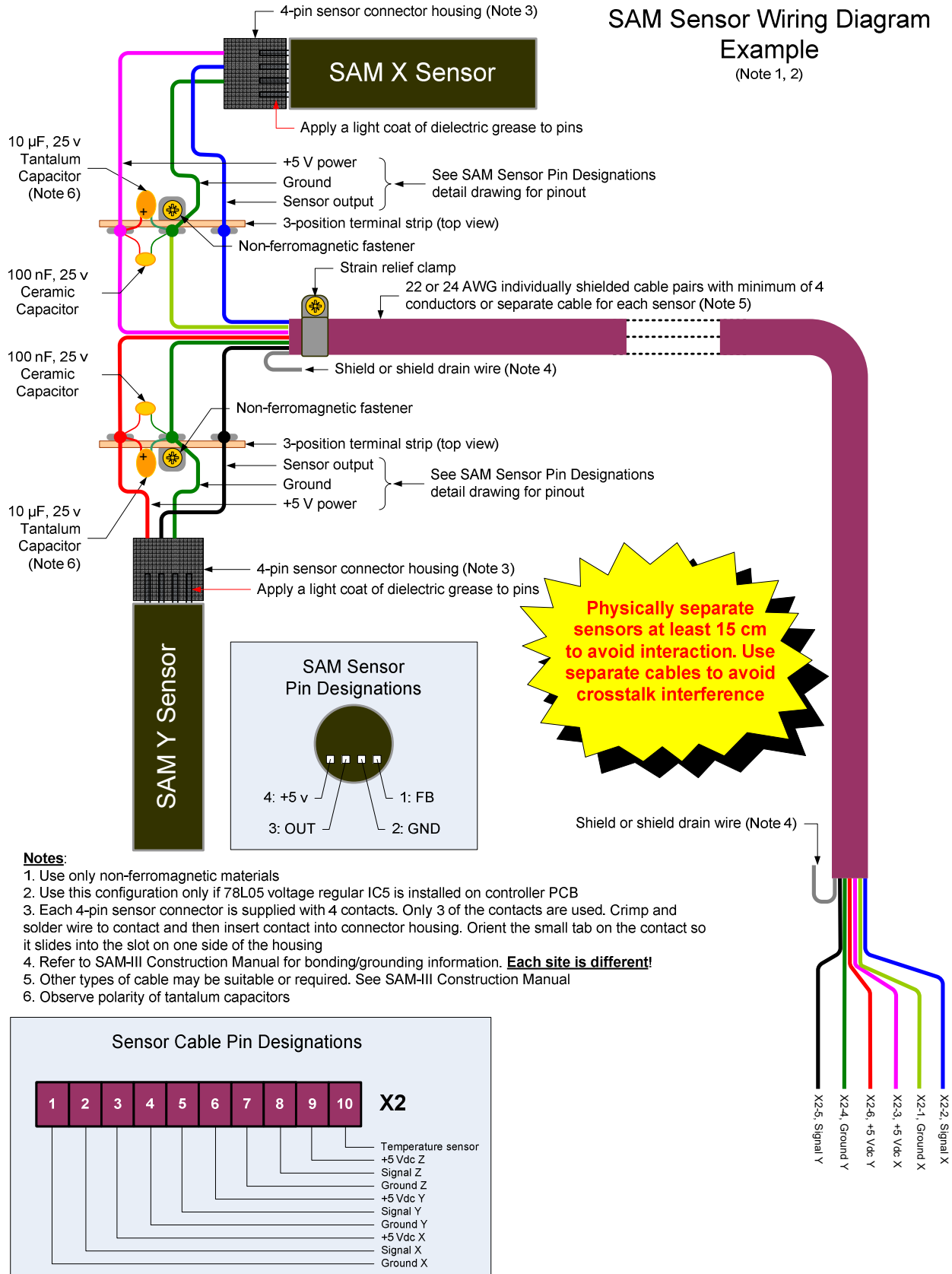

SAM-III Construction Manual

Sensor power

Each sensor is powered by a dedicated +5 V voltage regulator on the SAM-III controller (78L05, U1, U3 and U4). Each sensor draws around 15 mA.

In some applications, it may be desirable to move the sensor voltage regulator from the SAM-III controller PCB to the sensor location to improve voltage regulation at the sensor. Only a minor change is required on the SAM-III controller PCB to accommodate a remote voltage regulator for each sensor (typically a 78L05). Remove U1, U3 and U4 from the controller PCB and install a jumper between the In and Out pin locations (these are the two outer pins as shown below). This modification applies +12 V dc to positions 3, 6, and 9 of the pluggable terminal block X2. With this modification, it is imperative that a +5 V voltage regulator be installed with each sensor to provide +5 V dc for sensor operation (applying more than 5 V to the sensor will damage it).

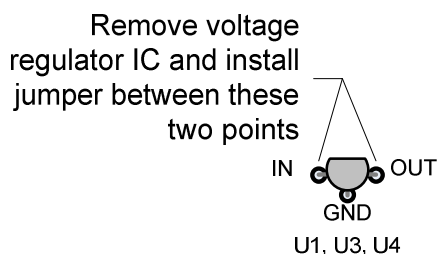

The wiring diagram for a remote voltage regulator at the sensor location is shown below for one sensor. This is an optional setup and is not used in a standard installation. Duplicate the wiring for all sensors. Note that filter capacitors are used at both the input and output of the voltage regulator. A small terminal block provides rigid terminations as shown in the accompanying photograph (the photograph shows a shop-built fixture, or “monkey cage”, for the sensor). Do not use any ferromagnetic components near the sensor.

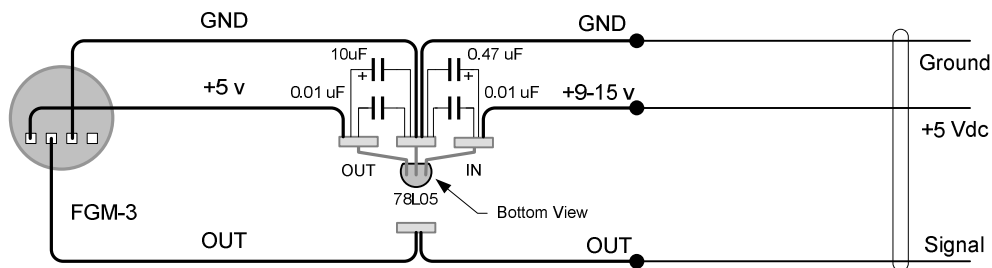

SAM-III Construction Manual



Sensor cable

The cable between the SAM-III controller and the sensors is user supplied. An installation with three magnetometer sensors and a temperature sensor will require a total of 9 conductors (10 conductors if using a temperature sensor). It is possible to share the ground conductor in installations if the cable is not too long (say less than 10 m). As discussed in the Mutual Interference section below, an installation of more than one sensor should use a separate cable for each sensor.

In general, the user-supplied cable should be shielded, such as coaxial cable or shielded twisted pair cable. For indoor installations Cat5 or better unshielded twisted pair cable is a suitable alternate cable (depending on the number of sensors it may be necessary to share the voltage or ground leads since the Cat5 cable has only 8 conductors).

The conductor gauge for short runs should be 24 AWG (0.5 mm) or larger. Longer runs should use 22 AWG (0.64 mm) or larger.

Where outdoor cable is exposed to the weather, it should be waterproof cable suitable for direct-buried applications (for example, waterproof shielded twisted pair telecommunications drop wire, type DBW).

Mutual interference

Mutual interference can be of two types: Interaction between sensors due to proximity and crosstalk interference.

Proximity: Sensors can interact with each other if mounted too close together. Therefore, in a 2-sensor or 3-sensor application, the sensors should be physically separated by at least 15 cm (6 in.). Some experimentation may be required to find the best separation. In geomagnetometer applications, the sensors are installed a right-angles to each other.

The photograph below shows a 2-sensor fixture made from nonmetallic conduit fittings. Each sensor is mounted in its own round junction box. The two boxes are glued to a piece of conduit at right angles

SAM-III Construction Manual

with sufficient separation. The third junction box at the bottom-right was used for test purposes and has a short DIN cable originally for the SAM-II. Even though the photograph shows fittings with screw-type covers, it is best to use glued fittings through-out to prevent water infiltration. Water or moisture will ruin the sensor connectors.

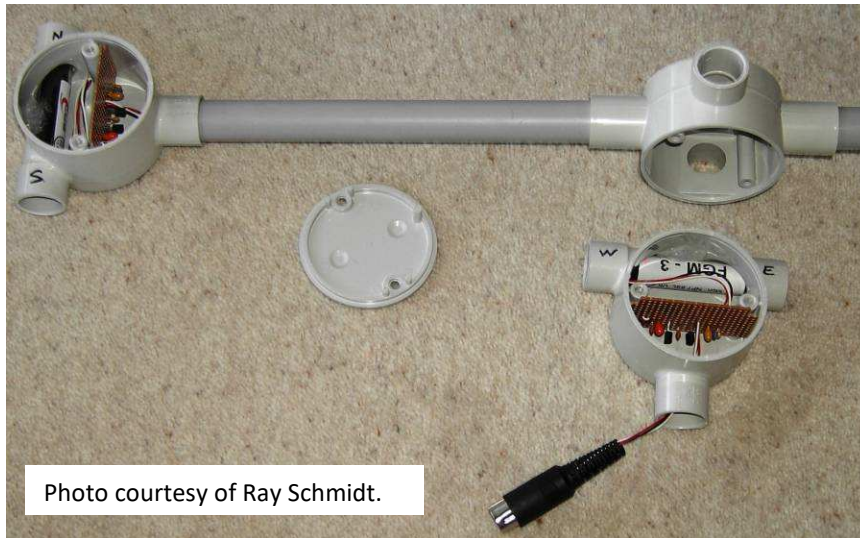

The following information was provided by Darrel Emerson, who performed some undocumented testing on the SAM-III sensors. If two sensors are parallel and too close, they tend to pull each other onto the same frequency. In the parallel configuration, it is recommended that the sensors be separated by at least 150 mm (6 in.) to minimize this effect. If the two sensors are at right angles to each other, the pulling effect is much smaller. The effect also depends on the alignment with the Earth's field. If the sensors are parallel, but one is rotated 180 degrees (so the pins are pointed in opposite directions), then for most alignments with respect to the Earth's field, the two sensor frequencies are quite different, and the pulling effect disappears. However, when their alignment with the Earth's field brings them both to nearly the same frequency, the frequency pulling effect is strong.

Crosstalk: When the signal outputs from two or three sensors are carried in the same cable from the magnetometer sensor location to the SAM-III processor module, the likelihood of crosstalk interference is very high. The outputs are unbalanced and easily couple into adjacent cable conductors and become part of the signal input from other sensors. There are at least a couple ways to solve the problem of crosstalk interference. One is to install circuitry at both ends of the cable that converts the sensor signal output to a balanced interface for transmission over balanced twisted pair cable and the other is to use a separate cable for each sensor.

In the first method, an EIA-485 balanced line driver such as the Texas Instruments SN65LBC184 differential transceiver may be used. Information on this application is available on request. In the second method, two shielded cables would be used in a 2-sensor installation, and three shielded cables would be used in a 3-sensor installation.

SAM-III Construction Manual

Crosstalk problems in an existing installation with a single cable, where it may be impractical to replace the cables or install a differential interface, may be reduced by using a low-pass filter in each sensor signal lead. The filters should be installed close to the SAM-III processor module. The filter characteristics are best determined experimentally, but a simple LC filter (above, by John DuBois) has worked well in some installations.

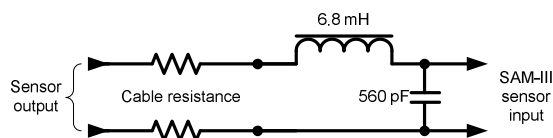

Radio Frequency Interference (RFI)

The SAM-III is susceptible to RFI from nearby amateur radio transmitters. The interference generally is picked up by the sensor cable. The sensor output is a PWM waveform with a maximum frequency of about 130 kHz. The SAM-III processor operates at 16 MHz and the sensor multiplexer (SN7400 quad NAND gate) operates at several megahertz. The interference usually manifests itself in the SAM-III as a geomagnetic storm because the SAM-III detects and counts the transmitter frequency or intermodulation products and not the sensor frequency. Here are some mitigation techniques that may help reduce faulty operation due to interference:

1. Different configurations of sensor cable shield bonding and grounding (bond to Earth at one or both ends, mid-point bond to Earth)
2. Burial of sensor cable
3. Low pass filter on the signal lead. (the low pass filter should have a cutoff frequency of 1 ~ 2 MHz)
4. Single-ended to differential transceiver on sensor signal lead (information available at: <http://www.marsport.org.uk/observatory/magmod.htm>)
5. Use the radio transmitter PTT to activate the input voltage detector. When +12 V dc is applied to pin 1 with respect to pin 2 of terminal block X1 the SAM stops measuring the sensor output. In this way, the SAM-III will ignore the interference during transmission. When the PTT is released, and +12 V dc removed from pin 1, the SAM-III resumes sensor measurements

Sensor testing

If power is applied to the SAM-III processor module but no sensors are connected, the display will appear similar to below. Other characters may be displayed on the right side of the display and additional characters or numbers may be shown on the bottom line.

X : _____
Y : _____
Z : _____

With no sensors connected, placing the processor module in Calibration Mode by pressing F2 will result in a display similar to below. Press F2 again to exit Calibration mode.

SAM-III Construction Manual

```
X: -82000/_____0Hz  
Y: -82000/_____0Hz  
Z: -82000/_____0Hz
```

When the sensors are connected and power is applied to the processor module, the display will show magnetic field induction values (in nT) after a moment and will look similar to below. The actual values are not important and will depend on the local environment and orientation of the sensors. For testing purposes, it is only necessary that the sensors display a value other than the default -82,000 nT. If one or two sensors are connected, only those fields will show magnetic induction values. The fields for sensors that are not connected will show -82,000 nT.

```
X: -12345/-21nT  
Y: 54321/5nT  
Z: 12332/43nT
```

If all three sensors are connected, placing the processor module in Calibration Mode by pressing F2 will result in a display similar to below. The actual values are not important and will depend on the local environment and orientation of the sensors. For testing purposes, it is only necessary that the sensors display a value other than -82,000 nT/0 Hz. If one or two sensors are connected, only those fields will show magnetic induction and frequency. The fields for sensors that are not connected will show -82,000 nT/0 Hz. Press F2 to exit Calibration mode.

```
X: 24324nT/46847Hz  
Y: 8013nT/55531Hz  
Z: 10013nT/45745Hz
```

If a frequency counter is connected to the output of each sensor, the counter should show a frequency close to the frequency on the SAM-III display when the processor module is in Calibration mode (the tolerance is not specified). Note: The sensor output is a logic level squarewave, and it is possible the frequency counter will measure an odd harmonic. A lowpass filter can be used to reduce harmonic levels.

The sensors have a normal operating range of approximately $\pm 50,000$ nT, which corresponds to a frequency range of approximately 125 kHz at -50,000 nT to 50 kHz at +50,000 nT. A magnetic induction of 0 nT corresponds to the frequency of about 70 kHz. These above values are given for reference and troubleshooting. They are not guaranteed in any way and users should expect variations.

It has been our experience that, if a magnetic induction value and frequency are shown in the appropriate sensor field of the display when the SAM-III is in Calibration mode, the sensors are connected and working properly. No additional testing or validation is required.

SAM-III Construction Manual

The SAM-III sensors are very sensitive and will give erratic readings when placed in an uncontrolled or magnetically noisy environment. It is a common mistake of first-time users to misinterpret the erratic readings as a malfunctioning sensor or SAM-III controller problem. Any tiny movement of the sensor or movement of metallic objects in the vicinity of the sensor will affect its output. When viewed on an oscilloscope, these output variations are manifested as rapid and erratic changes in the measured pulse period.

Users wishing to perform more detailed tests or calibrations will need to build a Helmholtz coil or a single-layer solenoid (coil) that is much longer than the sensor. The design, construction and test details of these devices are beyond the scope of this manual.

SAM-III Construction Manual

XVI. Magnetometer Sensor Installation

Read this entire section before installing the magnetometer sensors

Orientation

Magnetic field components

It is first necessary to decide what component or components of the magnetic field are to be measured. The SAM-III supports one, two or three sensors, so it may be setup to measure the following combinations:

1-sensor installation, one of the following	2-sensor installation, one of the following	3-sensor installation
X	X and Y	X, Y and Z
Y	X and Z	
Z	Y and Z	

A 1-sensor installation often is setup to measure the Y-component and a 2-sensor installation is setup to measure the X- and Y-components, but it is a matter of personal choice which components are to be measured. It is best to stay with the three components and not use arbitrary orientations. Each sensor is labeled in the SAM-III software for one of the three magnetic field components and arbitrary orientations are not specifically supported.

Generally, it is the Y-component that is affected most by geomagnetic storms. The K-index reported by professional observatories is based on the vector sum of the X- and Y-component (horizontal). For aurora watchers and amateur radio operators that take advantage of propagation opportunities caused by geomagnetic disturbances, variations in the Y-component are of the most value. However, the other components also show interesting variations, especially at higher latitudes, so they should not be discounted from consideration when you are contemplating your sensor installation. The Z-component (vertical) normally is influenced most by induced electric currents in the Earth's crust. These currents could be from local sources (for example, currents due to nearby powerlines), the anomalous field component and remnant magnetism or local ore bodies.

Transient magnetic variations are of interest to SAM-III users. These usually are broken into three basic categories: Solar daily variations (S), lunar daily variations (L) and magnetic disturbances (D). How each magnetic component is affected by these variations is beyond the scope of this manual. For additional information, SAM-III users are referred to online sources. Also, SAM-III users should download and read *Geomagnetism Tutorial* from this internet address:

<http://www.reeve.com/Documents/SAM/GeomagnetismTutorial.pdf>

SAM-III Construction Manual

Also, probably one of the best references on the Earth's magnetic field ever written is *Geomagnetism*, Vol. I and II, by S. Chapman and J. Bartels. This 2-volume set originally was published in 1940 and is available from online used-book sellers.

Sensor body direction

For correct measurement of the magnetic field, the sensor body and pins must be oriented as shown in the table below. If the orientation is backwards, changes in the measured induction will be displayed opposite to actual (for example, a positive change will be displayed as a negative change).

Magnetic field component	Sensor body orientation	Pins direction
X	North – South	SOUTH
Y	East – West	WEST
Z	Vertical	UP

When sensors are setup to measure the X- and Y-components, the sensors are installed perfectly horizontal. When a sensor is setup to measure the Z component, it is installed perfectly vertical. In an installation with more than one sensor, all sensors are rigidly and accurately mounted at right-angles to each other. However, the sensors must be physically separated as discussed in the previous section.

The rotational orientation of the sensor's longitudinal axis does not matter. Once its longitudinal axis is pointed properly, the body can be rotated and it will not change the measurements.

Coordinate Systems

One of three coordinate systems is used in professional observatories, two based on geographic coordinates and one on geomagnetic coordinates:

- Geographic coordinates – North (X), East (Y), Vertical down (Z)
- Geographic coordinates – Horizontal intensity (H), Declination (D), Vertical down (Z)
- Geomagnetic coordinates – Magnetic north (H), magnetic east (D), Vertical down (Z)

The geographic coordinate systems use true north as reference, and the geomagnetic coordinate system uses magnetic north as reference. The one you chose is up to you, but the advantage of using geographic coordinates is that you always know what coordinate system you are in. The geomagnetic coordinate system drifts with time - if you perfectly align one of your sensors with magnetic north today, it will be out of alignment tomorrow. Refer to the *Geomagnetism Tutorial* for additional information.

The standard for the SAM Magnetometer Network project is *geographic coordinates*, X, Y and Z, with reference to true north. This means the N-S sensor is installed with the cylinder axis horizontal and pointed toward true north. The E-W sensor is installed with the cylinder axis horizontal and pointed 90 degrees with respect to true north. The vertical sensor is installed with the cylinder axis pointed vertically. The sensor pins must be oriented as discussed above.

SAM-III Construction Manual

Environment

Temperature

The SAM-III sensor is very sensitive to temperature variations. The temperature coefficient is approximately -100 to -150 nT/°C (the minus sign indicates that the amplitude increases as the temperature decreases). To minimize temperature effects, the sensors must be insulated from temperature changes in their environment. However, it has been reported that the sensor can overheat if insulation is applied directly to it. Therefore, when an insulated enclosure is used, there should be space around the sensor to allow convection and radiation cooling.

Burial in earth to reduce sensor temperature variations

Placing the sensors in a watertight fixture and burying the fixture 0.5 to 1.5 m (or more) below the soil surface is a viable method to eliminate or greatly reduce diurnal temperature variations at the sensor. The watertight sensor enclosure can be placed in a small foam picnic cooler with additional thermal insulating foam fitted around the fixture and the entire assembly then buried in the earth. The cooler should have at least one hole in the bottom to allow drainage.

Burying the sensors at a reasonable depth will eliminate diurnal temperature effects but will not eliminate seasonal temperature effects. It is relatively simple to calculate the soil temperature at depth by making assumptions about the soil thermal characteristics. Of course, these assumptions are made at the expense of accuracy but they provide a good starting point. Burial depth calculations are described in [Burial Depth of SAM-III Magnetometer Sensors](#).

When the sensors are buried, in soil their outputs will drift upwards as they become accustomed to the cooler environment. It may take more than a week for the temperature of the sensors to stabilize depending on the fixture insulation and their depth.

When the sensors are buried in soil, they must be sealed to prevent moisture intrusion. A sensor enclosure buried 1 m below the surface will be subjected to a hydrostatic pressure of 1 m head of water during rain and when the ground is water saturated. This pressure is equivalent to 1.4 pounds/sq. inch or about 10 kilopascals, a nominally small amount but enough to force water through even the smallest pinholes or defects in the enclosure seals. A drawing of a sensor enclosure using commonly available materials (in the United States) is shown at the end of this section.

Because copper wires are very good thermal conductors, the cables feeding the sensor installation also must be buried at the same depth as the sensors for a distance of at least 1 m and preferably more from the sensor fixture. Do not place the cables horizontally to above the sensor location and then drop directly down to the sensors.

Location

Place the sensors in a magnetically quiet location where they will experience as little local magnetic disturbance as possible, usually in an open field or yard away from any buildings and automobile traffic.

SAM-III Construction Manual

Ferromagnetic objects within the vicinity of the sensor generally do not cause problems if their location is permanent and they do not become magnetized.

Bury the fixture in a shady area to prevent direct sunlight on the soil surface above the sensors. Do not disturb foliage surrounding the sensor area and, if no foliage is present, consider planting shrubs and bushes to shield the soil surface above the sensors from direct sunlight.

It is important to remember that the magnetic sensor will pick up any variation in the local magnetic field including automobiles, trucks and trains moving in the area, ferromagnetic tools brought nearby and other manmade magnetic disturbances.

Any movement of the sensor or movement of ferromagnetic materials in its vicinity will cause a variation in the magnetic field measurements. Therefore, after any movement it usually is necessary to re-zero the SAM processor by pressing the F3 function key (Reset). Alternately, let the magnetometer run and it will re-zero itself within 24 hours.

Field Use

The SAM-III sensors have proven to be very robust in the field and have survived incorrect signal and power connections and shock from being dropped. However, they should never be routinely treated that way. The sensor is encapsulated in an epoxy-like compound, which can be cracked and broken. Also, the pins are fairly fragile and if bent back and forth will break. Broken pins are not repairable.

SAM-III Construction Manual

Buried Sensor Fixture – Single-sensor installation, Typical

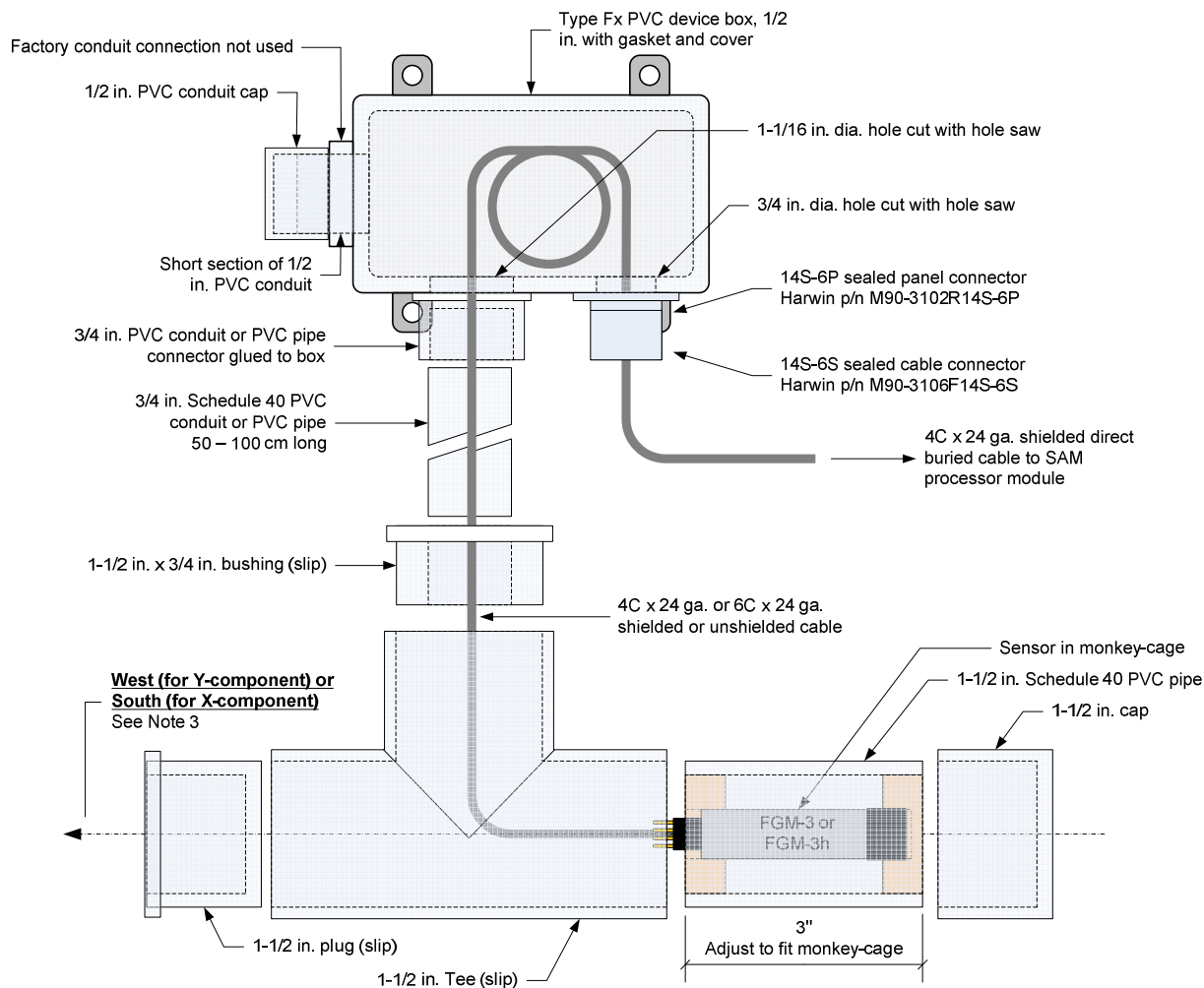

Notes:

1. All pipe and conduit sizes are non-metric trade sizes
2. All joints double-glued, once to assemble and again to provide additional seal
3. This fixture for horizontal sensing (E-W or N-S) only; orient as shown

Bill of Material

Qty	Description
1 ea.	Fx PVC device box, 1/2 in.
1 ea.	Device box cover, gasket
1 ea.	1/2 in. PVC conduit cap
1 ea.	3/4 in. PVC conduit connector
1 ea.	3/4 in. Sch. 40 PVC pipe, 40 in. long
1 ea.	1-1/2 in. x 3/4 in. PVC slip bushing
1 ea.	1-1/2 in. PVC slip Tee
1 ea.	1-1/2 in. PVC slip plug
1 ea.	1-1/2 in. PVC pipe cap
1 ea.	14S-6P sealed panel connector
1 ea.	14S-6S sealed cable connector
1 ea.	4C x 24 AWG or 6C x 24 AWG unshielded cable, 60 in. long
1 ea.	4C x 24 AWG shielded direct buried cable, as req'd

SAM-III Construction Manual

Buried Sensor Fixture – Three-sensor installation, Typical (all components in USA trade sizes)

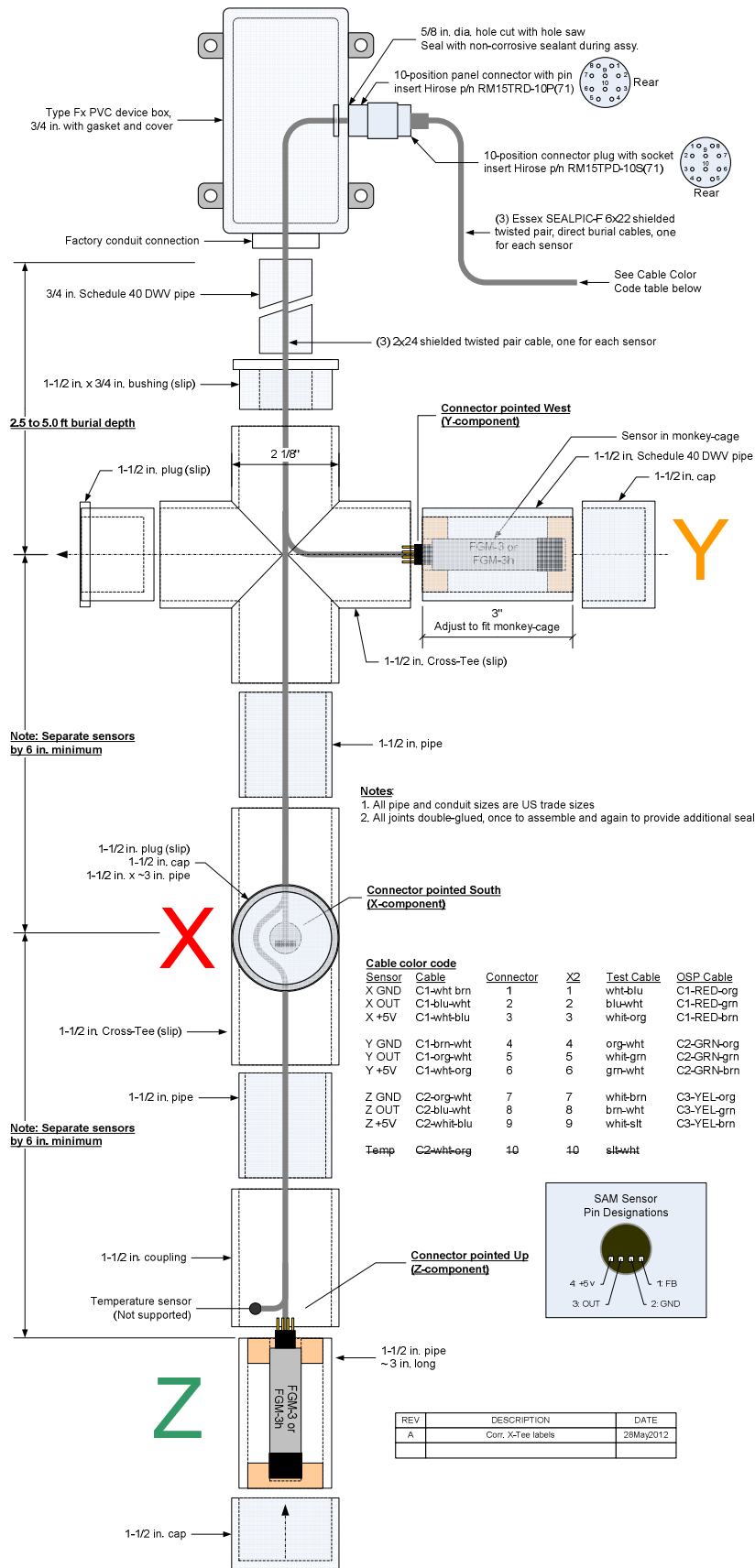

SAM-III Construction Manual

XVII. Temperature Sensor

Description

Note: The temperature sensor option is no longer supported. The only information available for it is described below.

If the SAM-III is loaded with the optional SAM3T_ENG.HEX operating system firmware, it has built-in capability to measure temperature using the Dallas Semiconductor/Maxim DS18B20 digital thermometer. The SAM3_HEX operating system firmware does not have this capability. The SAM3T_ENG.HEX firmware can be loaded using pic_downloader as described in sect. XII.

The DS18B20 uses a 1-wire bus protocol and measures temperature from -55°C to +125°C. Between -10°C and +85°C it has an absolute accuracy of $\pm 0.5^\circ\text{C}$. Maximum resolution is 0.0625°C (12-bit).

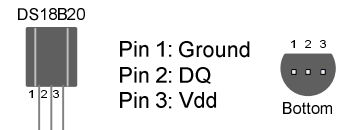

Note: Because the 1-wire bus protocol was not designed for distance, the temperature sensor cannot be located more than approximately 2 m from the SAM-III processor module. This precludes collocating the temperature sensor with the magnetometer sensors where the magnetometer sensors are remotely located (which will be the case in almost all applications).

The SAM-III hardware and application software do not use or display the temperature data; the SAM-III reads the temperature from the DS18B20 and sends it along with magnetometer sensor induction values in the data stream for later access by the user. The temperature sensor generally would be located with the magnetometer sensors to obtain temperature data for downstream correlation of magnetometer sensor drift with temperature. When the SAM-III is powered up, the operating system software initializes the magnetic sensors (~10 seconds) and then addresses the DS18B20.

The temperature is not displayed on the LCD because there is no room for it. The temperature data is included in the SAM-III data stream only if a digital thermometer is detected. If a digital thermometer is not detected, the data stream will not include temperature data.

The temperature sensor is connected as shown below. The schematic shows two filter capacitors, a high-value tantalum capacitor across the Vdd input and a small multilayer ceramic capacitor across the DQ data output. These capacitors normally are needed only when there is interference to the temperature sensor input/output due to a long sensor cable.

SAM-III Construction Manual

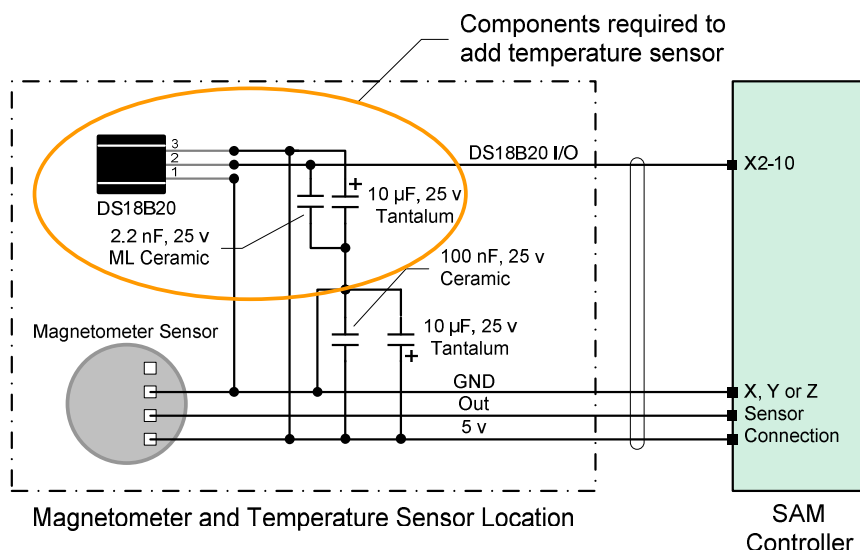

Temperature sensor test:

After installing the digital thermometer, turn on power to the SAM-III and then run SAM_VIEW. Go to the directory or folder where SAM_VIEW stores the data (specified in Edit – Setup – Logging – Data Directory). After a moment, some .txt and .log files will appear. Open the sam_data.txt file and look in the last column to the right of the Z-sensor data values. The temperature should be shown. See example below. Gaps in the temperature data are normal.

```
DD.MM.YY HH:MM:SS: X, DDDD, Y, DDDDD, Z, DDDDD, TT.T
```

```
28.07.10 22:13:58: X, 6809, Y, 44871, Z, -7992, 22.8
28.07.10 22:14:00: X, 6809, Y, 44871, Z, -7992, 22.8
28.07.10 22:14:02: X, 6809, Y, 44871, Z, -7992, 22.8
28.07.10 22:14:04: X, 6809, Y, 44871, Z, -7992
28.07.10 22:14:06: X, 6809, Y, 44871, Z, -7992, 22.8
28.07.10 22:14:08: X, 6808, Y, 44871, Z, -7992, 22.8
28.07.10 22:14:10: X, 6808, Y, 44871, Z, -7992, 22.8
28.07.10 22:14:13: X, 6808, Y, 44868, Z, -7992
28.07.10 22:14:15: X, 6808, Y, 44868, Z, -7992, 22.7
28.07.10 22:14:17: X, 6808, Y, 44868, Z, -7992
28.07.10 22:14:19: X, 6808, Y, 44868, Z, -7992, 22.7
```

SAM-III Construction Manual

XVIII. Circuit Description:

The SAM-III is a microprocessor-controlled system that measures the output from up to three SAM-III fluxgate magnetometer sensors. Ancillary functions include an EAI-232 interface for data logging and setup, an optical isolated input to stop measurements and prevent erroneous sensor input during radio transmissions, an alarm output and a K-index output in analog voltage format. While reading the circuit description, refer to the block diagram below and the schematics and PCB layouts on the following pages.

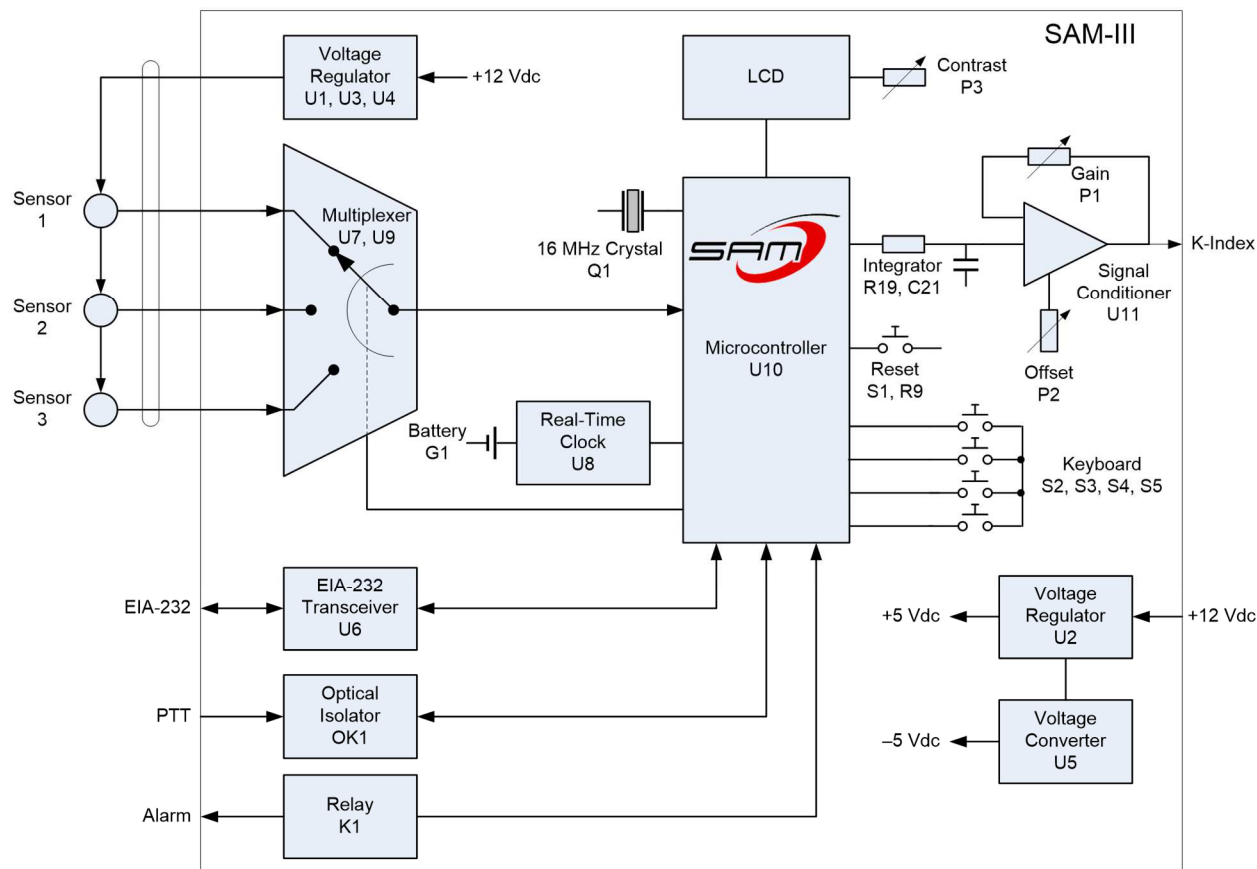

The microprocessor, U10, controls all functions and operates at 16 MHz as determined by the crystal, Q1, and associated crystal load capacitors, C19 and C20. The microprocessor may be reset using the pushbutton switch, S1, and associated pull-up resistor, R9. The real-time clock integrated circuit, U8, has an internal crystal (10 or 50 parts per million frequency precision, depending on part number) and keeps track of date and time. The SAM-III includes a battery, G1, and voltage steering diodes, D3 and D4, for the real-time clock. Terminal block JP2 allows the battery to be disconnected. A pull-down resistor, R11, is used for U8 chip select.

The SAM-III sensors are fluxgate magnetic field sensors that convert the measured magnetic induction, or magnetic flux density, to a pulse width modulated (PWM) signal. The sensor output is connected to a simple controlled gate multiplexer consisting of U7 and U9 and associated 10 kohm load resistors. The multiplexer is under control of the microprocessor RC1 and RC3 programmable outputs (see oscilloscope images below). Each sensor is read in turn. The PWM waveform pulse period connects to the

SAM-III Construction Manual

microprocessor programmable input RC0. The waveform is measured by counters in the microprocessor and converted to a magnetic induction value according to a linear relationship between the magnetic induction and pulse period. It is known that the SAM-III sensors are temperature sensitive; however, no temperature compensation is provided in the SAM-III.

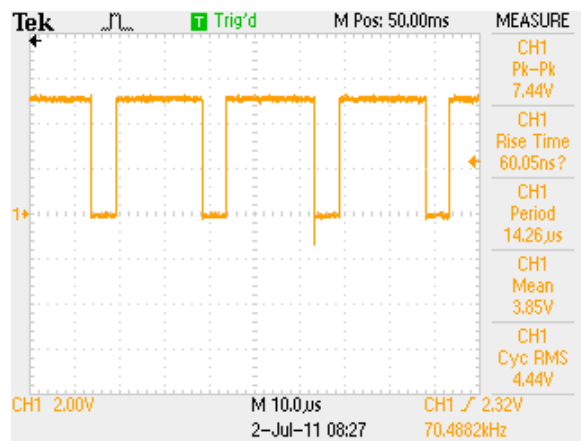
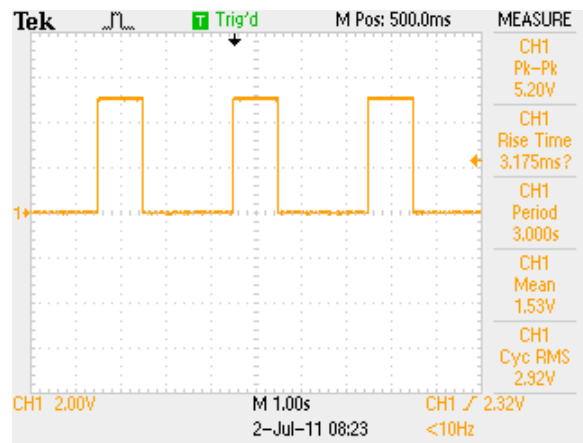
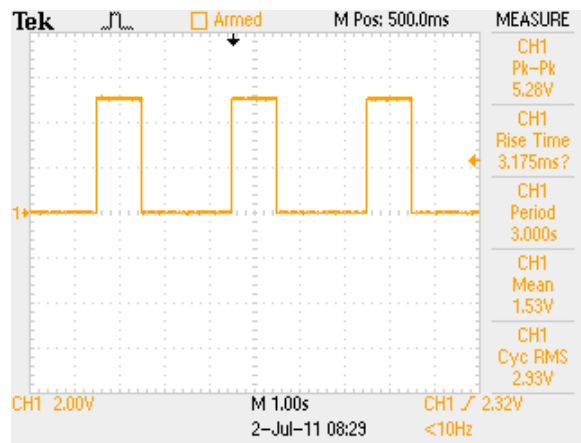

The three scope images show, in order, U10 pin 16 and 18 (programmable outputs RC1 and RC3 to multiplexer) and pin 15 (programmable input RC0 from sensors)

The magnetic induction and other information are displayed on the liquid crystal display (LCD) module. The LCD is provided with a contrast control, P3, and the backlight is controlled through a transistor switch consisting of R16, R20 and Q2.

The SAM-III also provides an analog output voltage that is proportional to the K-index. The microprocessor RC2 programmable output provides a PWM signal that is proportional to the K-index. An RC integrator or low pass filter, R19 and C21, smoothes the PWM output (period proportional to K-index). This is applied to a dual operational amplifier, U11, which provides signal conditioning and buffering. The gain of the input operational amplifier is set by R14, P1 and R15. The unity-gain buffer, or output, stage includes R13, R17, R18, R21 and offset control P2.

The sensor measurements are combined with the time and date and sent to the EIA-232 transceiver, U6, via the RC6 programmable output of the microprocessor. The transceiver also sends EIA-232 data for setup purposes to the microprocessor through the microprocessor RC7 programmable input. This input channel normally is used only during setup of the SAM-III. Capacitors, C15, C16, C17 and C18, are charge pump capacitors necessary for the operation of the EIA-232 transceiver, whose main function is to convert the microprocessor TTL/CMOS voltage levels (0 and 5 V) to EIA-232 voltage levels (typically ± 5 V) and to provide protection against electrostatic discharge (ESD).

SAM-III Construction Manual

A four-button keyboard, consisting of S2, S3, S4 and S5, associated pull-down resistors R3, R4, R5, and R6, and isolating diode, D2, are used to control the SAM-III. The keyboard PCB also has an indicator LED, D5. Resistor, R7, provides current limiting for the LED.

A transmitter push-to-talk control may be connected to the optical isolator, OK1, and microprocessor RC5 programmable input. When the PTT is keyed, the SAM-III stops measurements. When the PTT is released, the SAM-III resumes measurements. This prevents erroneous measurements during periods of possible radio frequency interference (RFI) from a nearby HF transmitter that may be operating in the same frequency range as the SAM-III sensor multiplexer.

The SAM-III provides an alarm output via the microprocessor RC4 programmable output and relay K1. When the preset K-index threshold is reached, the SAM-III operates the relay, which may be used to activate a warning lamp or external relay for a buzzer.

Not shown in the block diagram (but shown on the schematic) is the temperature sensor input to the microprocessor programmable input RA4 and associated pull-up resistor, R22. This is a Dallas Semiconductor 1-wire bus for connection to the DS18B20 temperature sensor.

Power is supplied to the electronics through a polarity guard diode, D1, and +5 Vdc voltage regulator, U2. A voltage converter, U5, converts the +5 Vdc output of the voltage regulator to -5 Vdc for the signal conditioner, U11. Also, each SAM-III sensor has its own +5 Vdc voltage regulator, U1, U3 and U4.

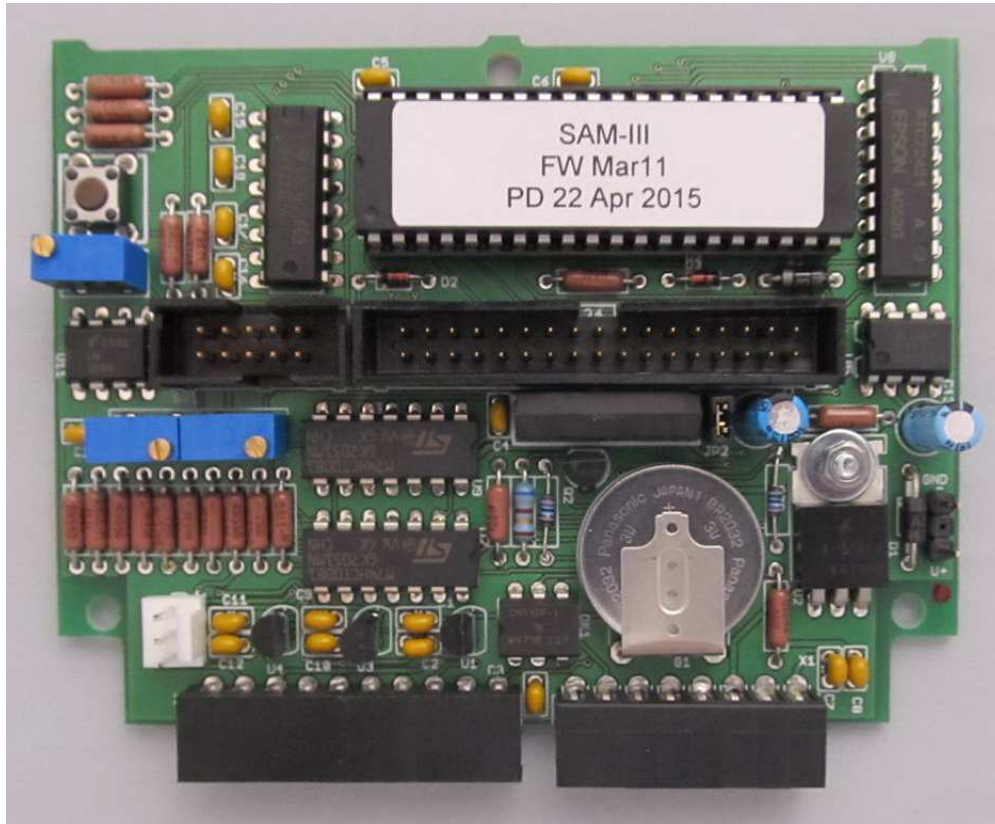

SAM-III Construction Manual

Main Controller Schematic Diagram

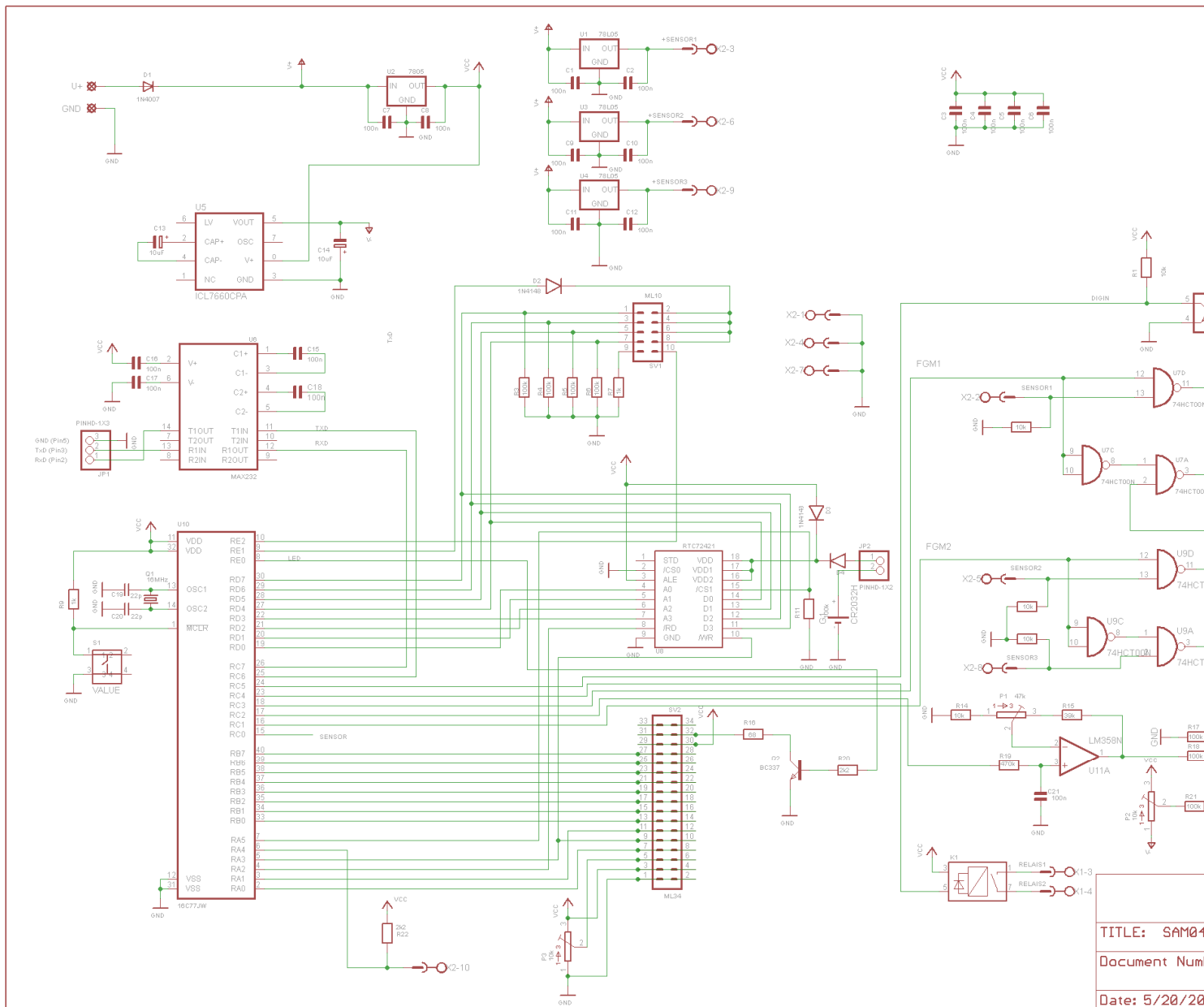

TITLE: SAM04
Document Num
Date: 5/20/20

SAM-III Construction Manual

Keyboard Schematic Diagram

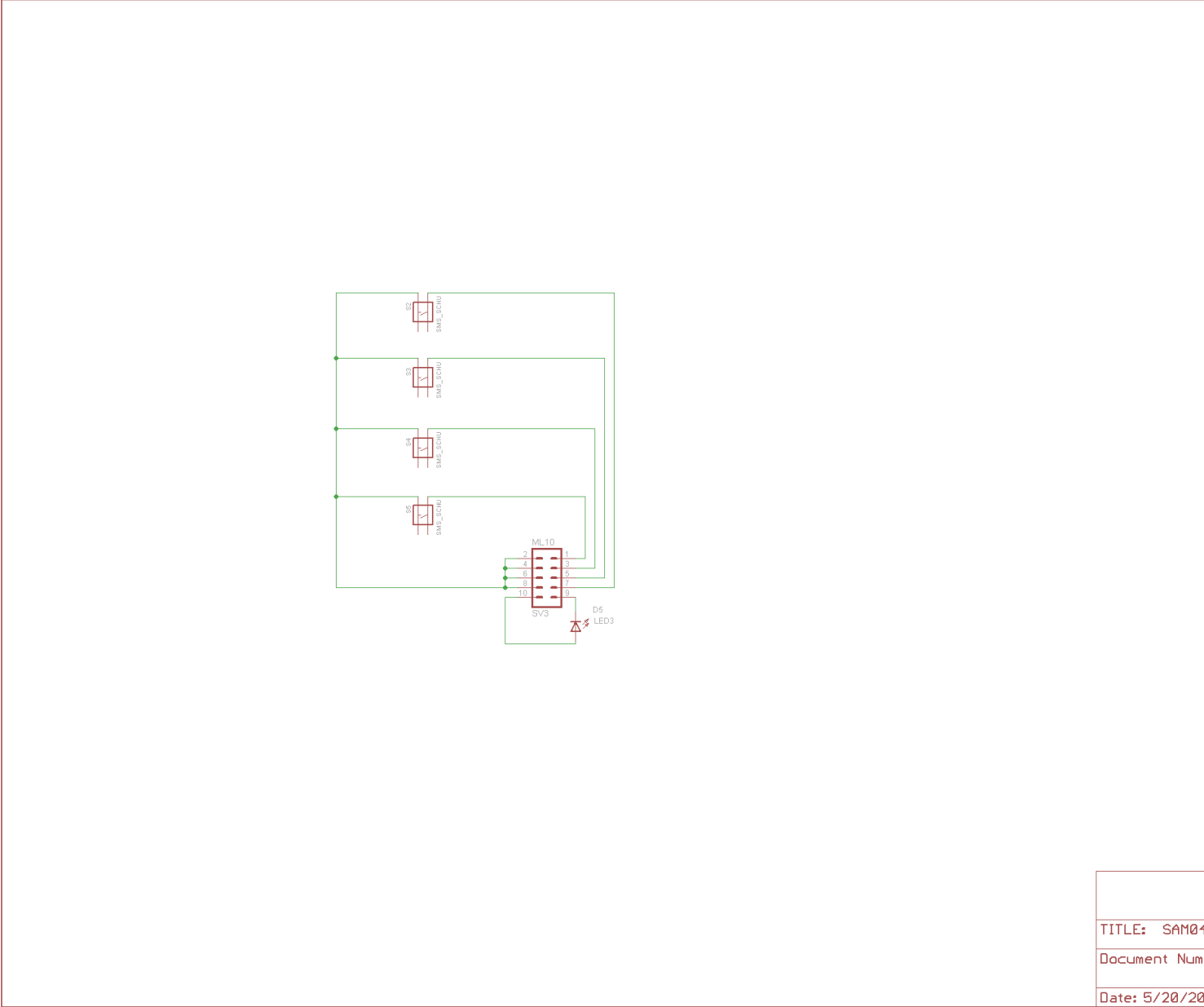

TITLE: SAM04
Document Num
Date: 5/20/20

SAM-III Construction Manual

PCB Component Layout

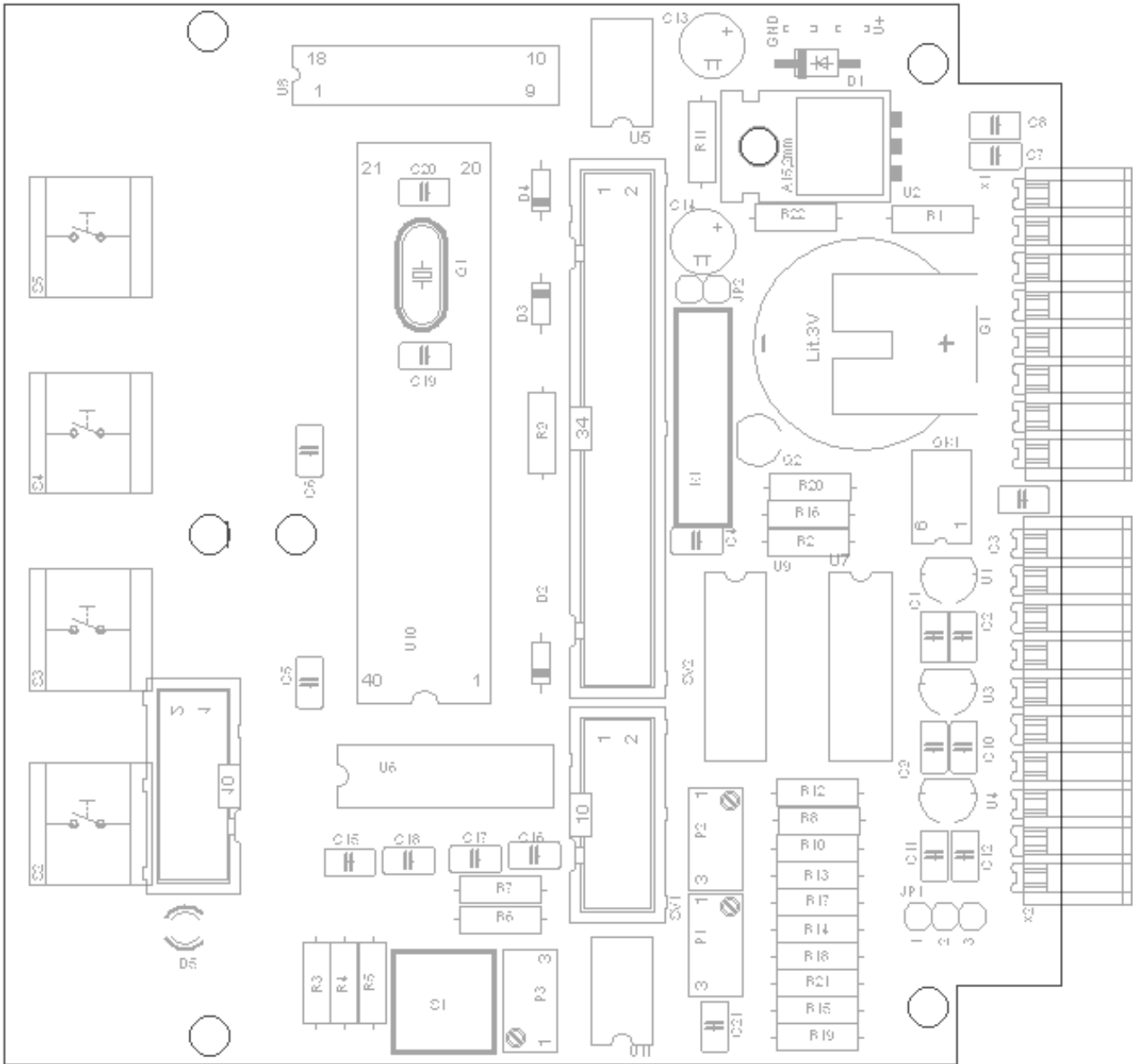



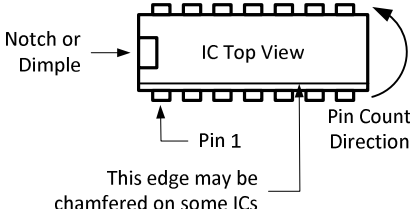

SAM-III Construction Manual

XIX. SAM-III Kit Components Identification Guide:

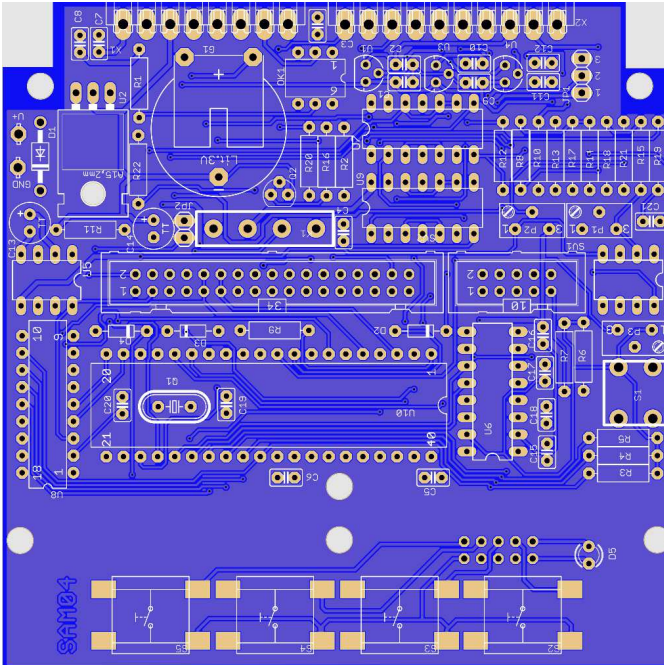









Use only for parts identification and not inventory. Images not scaled.

 <p>Notch or Dimple →</p> <p>IC Top View</p> <p>Pin 1</p> <p>Pin Count Direction</p> <p>This edge may be chamfered on some ICs</p>	<p>READ and FOLLOW the CONSTRUCTION MANUAL !</p>	<p>Abbreviations:</p> <p>DIL-x: Dual InLine package, x pins</p> <p>LCD: Liquid Crystal Display</p> <p>PCB: Printed Circuit Board</p> <p>SIL: Single InLine package</p> <p>▶ : Polarity Alert</p>
---	---	---



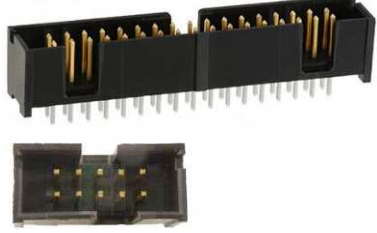





<p><u>Printed Circuit Boards:</u> Main Controller PCB (upper) & Keyboard PCB (lower). Various colors including blue, green and red. The images show the TOP or COMPONENT or SILKSCREEN SIDE of the PCBs. The silkscreen outlines for each component indicate required polarity. Integrated circuits have a polarizing notch at one end. Align integrated circuits to match outline. ALL COMPONENTS ARE INSTALLED ON THE COMPONENT SIDE OF THE PCBs EXCEPT THE CONNECTOR ON THE KEYBOARD PCB. Follow the instructions.</p> <p><u>Note:</u> Early versions of the PCB had the keyboard connected to the main PCB with webs that required cutting with a hobby saw or hacksaw. Cut very carefully; see Construction Manual</p>	
--	---

<u>Item</u>	<u>Representative image</u>	<u>Polarity Alert</u>
<p><u>Keyboard Components:</u> Pushbutton, Surface mounted. S2, S3, S4, S5.</p>		<p>Non-polar</p>
<p><u>Keyboard Components:</u> Light Emitting Diode (LED), Red.</p>		<p>▶ Long lead is Anode (+). See Construction Manual.</p>
<p><u>Keyboard Components:</u> 10-pin Connector. Note polarizing notch – use only center notch for proper placement. This is the only component installed on the BOTTOM of the PCB.</p>		<p>▶ Note the centered polarizing notch at top of image. Some connectors may have more than one notch. Match <u>centered</u> notch to PCB.</p>



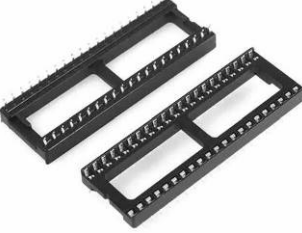







SAM-III Construction Manual

<p><u>Power Supply Components:</u> Resistors ~ Some may have solid body color with value marked, some may be color-coded with stripes. See Resistor Chart at end. Verify all values with an ohmmeter.</p>		<p>Non-polar. See Resistor Chart at end. For viewing ease, align all resistors with the tolerance band to the right.</p>
<p><u>Power Supply Components:</u> Ceramic Capacitors ~ Capacitance value marked as code 104 or 100n. Body color may be blue or gold.</p>		<p>Non-polar.</p>
<p><u>Power Supply Components:</u> Electrolytic Capacitors ~ Capacitance value & voltage marked on body. Various body colors including blue, black and gray.</p>		<p>► Positive (+) is long lead. Negative (-) is marked on body with stripes.</p>
<p><u>Power Supply Components:</u> 1N4148 Diode ~ Type marked on body.</p>		<p>► Black stripe around body indicates Cathode (-). Match stripe to PCB.</p>
<p><u>Power Supply Components:</u> 1N5819 Diode ~ Type marked on body.</p>		<p>► Silver stripe around body indicates Cathode (-). Match stripe to PCB.</p>
<p><u>Power Supply Components:</u> 1N4007 Diode ~ Type marked on body.</p>		<p>► Silver stripe around body indicates Cathode (-). Match stripe to PCB.</p>
<p><u>Power Supply Components:</u> Connectors, 34-pin & 10-pin. Note polarizing notch. Use only the center polarizing notch for proper placement.</p>		<p>► Note the centered polarizing notch at top of images. Some connectors have more than one notch. Match <u>centered</u> notch to PCB.</p>
<p><u>Integrated Circuits:</u> 78L05 Voltage Regulator. Type marked on body. U1, U3, U4</p>		<p>► Match flat side to PCB.</p>
<p><u>Integrated Circuits:</u> 7805 Voltage Regulator. See Construction Manual for lead bending. Type marked on body. U2</p>		<p>► Metal tab is mounted against PCB.</p>
<p><u>Integrated Circuits:</u> 7660 Voltage Converter. DIL-8. Type marked on body. Pin 1 lower-left corner below end-notch. U5</p>		<p>► Match notch or dimple at end of IC with PCB.</p>
<p><u>Integrated Circuits:</u> MAX232x or SP232x Transceiver. DIL-16. Type marked on body. Pin 1 lower-left corner below end-notch. U6</p>		<p>► Match notch or dimple at end of IC with PCB.</p>









SAM-III Construction Manual

<p><u>Integrated Circuits:</u> 74HC00 NAND Gate. DIL-14. Type marked on body. Pin 1 lower-left corner below end-notch. U7 & U9</p>		<p>▶ Match notch or dimple at end of IC with PCB.</p>
<p><u>Integrated Circuits:</u> RTC72421x Real-Time Clock. DIL-18. Type marked on body. Pin 1 lower-left corner below end-notch. U8</p>		<p>▶ Match notch or dimple at end of IC with PCB.</p>
<p><u>Integrated Circuits:</u> LM358x Op-Amp. DIL-8. Type marked on body. Pin 1 lower-left corner below end-notch. U11</p>		<p>▶ Match notch or dimple at end of IC with PCB.</p>
<p><u>Integrated Circuits:</u> CY17F-1 Opto-Isolator. DIL-6. Type marked on body. Pin 1 lower-left corner below end-notch or chamfered edge. OK1</p>		<p>▶ Match notch at end or chamfered edge of IC with PCB.</p>
<p><u>Integrated Circuits:</u> PIC16F877-20/P Microcontroller. DIL-40. Pin 1 lower-left corner below end-notch. U10</p>		<p>▶ Match notch or dimple at end of IC with PCB.</p>
<p><u>Integrated Circuits:</u> 40-Pin DIL Socket for Microcontroller. Image shows top and bottom. Pin 1 lower-left corner below notch. U10</p>		<p>▶ Match notch at end with PCB.</p>
<p><u>Electromechanical 1:</u> Male Header 3-Pin, Latching Type. JP1</p>		<p>▶ Install with latching tab away from PCB edge. See Construction Manual.</p>
<p><u>Electromechanical 1:</u> Male Header & Shorting Block, 2-Pin. Various colors. JP2</p>		<p>Non-polar. Install shorter pins in PCB.</p>
<p><u>Electromechanical 1:</u> Single Inline (SIL) Relay. K1</p>		<p>▶ See Construction Manual for alignment.</p>
<p><u>Electromechanical 1:</u> Tactile Pushbutton Switch. S1</p>		<p>Non-polar but will fit easily only two ways.</p>





SAM-III Construction Manual

<p><u>Electromechanical 1</u>: Trimmer resistor. 50k or 47k. Value marked on body. Body color may be blue or gray. Image shows example. P1</p>		<p>Non-polar but will fit only one way.</p>
<p><u>Electromechanical 1</u>: Trimmer resistor. 10k. Value marked on body. Body color may be blue or gray. Image shows example. P2, P3</p>		<p>Non-polar but will fit only one way.</p>
<p><u>Electromechanical 1</u>: Ceramic Capacitor. Value marked on body, typically 22. Body color may be blue or gold. C19 & C20</p>		<p>Non-polar. Do not confuse with other ceramic (MLCC) capacitors.</p>
<p><u>Electromechanical 1</u>: Quartz Crystal. Q1</p>		<p>Non-polar. See Construction Manual.</p>
<p><u>Electromechanical 1</u>: Transistor. BC337. Q2</p>		<p>► Match flat side to PCB.</p>
<p><u>Electromechanical 1</u>: 4-40 hardware. 4-40 x 5/16 inch machine screw, (2) flat washers, split lock washer, small pattern hex nut.</p>		<p>Install machine screw and (1) flat washer from bottom of PCB. See Construction Manual.</p>
<p><u>Electromechanical 2</u>: Pluggable Terminal Block. 8-pin & 10-Pin. Various colors including green and black. Images show examples. X1 & X2, XP1 & XP2.</p>		<p>Non-polar but must be oriented with sockets pointed away from PCB.</p>
<p><u>Electromechanical 3</u>: Male Header Power connector, Latching, Modified. 3-position, 2-pin, 1-0-1 Configuration (center pin removed). Image is typical.</p>		<p>► Install with latch toward edge of PCB.</p>
<p><u>Electromechanical 3</u>: Female Wire Housing Power connector, Latching. 3-positions but only the two outer positions are used.</p>		<p>► Latching tab. See Construction Manual for orientation.</p>
<p><u>Electromechanical 3</u>: Crimp Socket Contact. Use contact only with above wire housing.</p>		<p>See Construction Manual.</p>

SAM-III Construction Manual

<p><u>Electromechanical 3</u>: Power Plug & Jack, 2.1 x 5.5 mm. Plug with locking ring shown although non-locking type may be supplied.</p>		<p>See Construction Manual for wiring.</p>
<p><u>Electromechanical 3</u>: Heat-Shrink Tubing. Various colors and sizes, nominal diameter 1/16 inch.</p>		<p>Use with the dc power jack and DB-9M connector.</p>
<p><u>Battery</u>: 3-Terminal PCB Mount, BR2032/GUN. G1</p>		<p>► Polarized and will fit PCB only one way. See Construction Manual for warning.</p>
<p><u>LCD Module with Modified 34-Position Connector</u>: Screen color may be blue-white or yellow-green-gray.</p>		<p>Connector already assembled to LCD PCB.</p>
<p><u>Ribbon Cables</u>: Preassembled.</p>		<p>Cables already assembled.</p>
<p><u>Serial Cable Connector</u>: DB-9M Panel-Mount Connector with Solder Cups.</p>		<p>See Construction Manual for wiring.</p>
<p><u>Serial Cable Connector</u>: Wire Housing, 3-Pin with Latching Ridge and polarizer.</p>		<p>► See Construction Manual for wiring.</p>
<p><u>Serial Cable Connector</u>: Spring-Type Crimp Terminal Contact. Use contact only with the above wire housing</p>		<p>See Construction Manual.</p>

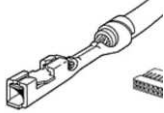
SAM-III Construction Manual

<p><u>Fluxgate Sensor</u>: FG-3+ sensor.</p>		<p>► See Construction Manual. Pins are marked on sticker and also in manual.</p>
<p><u>Fluxgate Sensor</u>: Female Wire Housing, 4-Pin.</p>		<p>► See Construction Manual. Connector housing not keyed.</p>
<p><u>Fluxgate Sensor</u>: Crimp socket Contact. Use contact only with the above wire housing.</p>		<p>See Construction Manual.</p>
<p><u>Fluxgate Sensor</u>: Filter Capacitor, Tantalum. Value marked on body.</p>		<p>► Long lead is positive (+). Positive polarity symbol also marked on body. See Construction Manual for installation.</p>
<p><u>Fluxgate Sensor</u>: Filter Capacitor, Ceramic. Value marked on body as a code 104 or 100n. Body color may be blue or gold.</p>		<p>Non-polar. See Construction Manual for installation.</p>

SAM-III Construction Manual

Resistor Charts

The SAM-III Kit may include resistors with solid body color or color coded stripes. Because of poor color contrast on many resistors, always verify values with an ohmmeter.

Value	Solid Body Marking
68.0 or 68.1 ohms	Always colored coded
1k or 1000 ohms	102
2k2, 2.2k or 2200 ohms	222
10k or 10 000 ohms	103
39k or 39 000 ohms	393
100k or 100 000 ohms	104
470k or 470 000 ohms	474

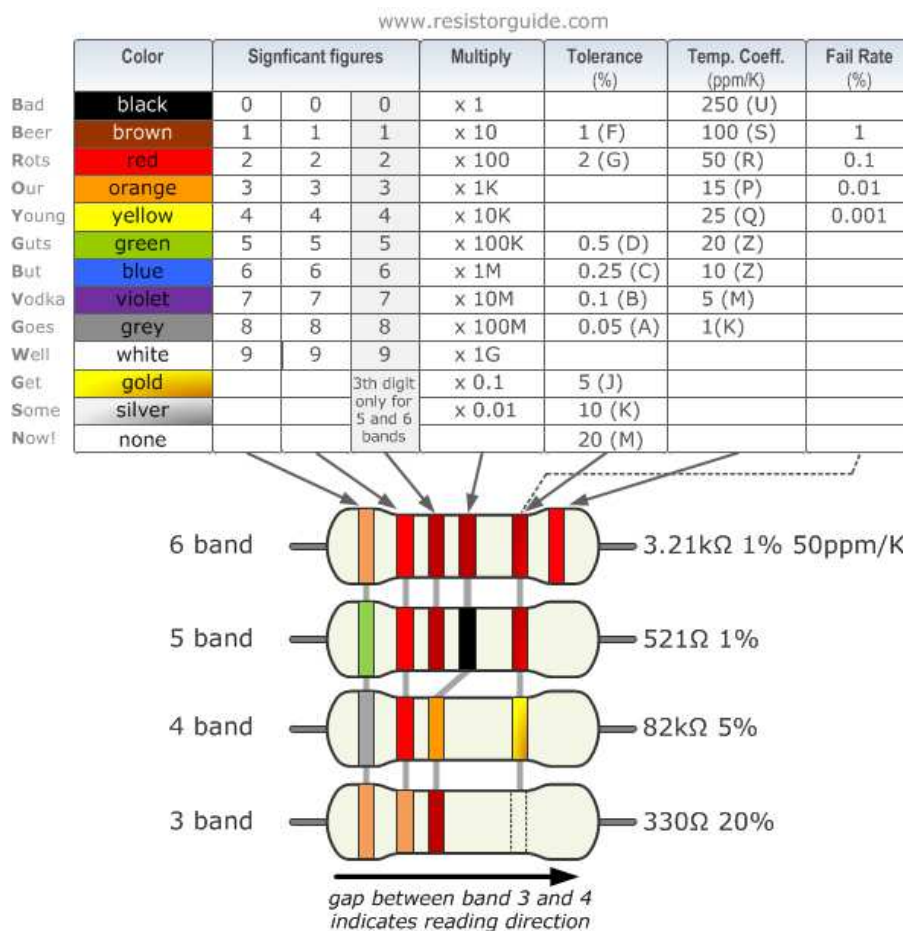

Notes: _____

SAM-III Construction Manual

Document History

<u>Author:</u>	Whitham D. Reeve, Anchorage, AK USA
<u>Copyright:</u>	© 2010 ~ 2018 W.D. Reeve
<u>Revision history:</u>	Iss. 0.0 (Initial draft started, June 11, 2010)
	Iss. 0.1 (Additional edits, July 9, 2010)
	Iss. 0.2 (Added serial port troubleshooting, July 21, 2010)
	Iss. 0.3 (Many edits from construction, July 25, 2010)
	Iss. 1.0 (Issued for publication, August 4, 2010)
	Iss. 1.1 (Update enclosure section, August 8, 2010)
	Iss. 1.2 (Minor edits, August 20, 2010)
	Iss. 1.3 (Edit coordinate systems, October 27, 2010)
	Iss. 1.4 (Add crosstalk and temp. sensor info, November 10, 2010)
	Iss. 1.5 (Add sensor info, correct analog out function, January 29, 2011)
	Iss. 1.6 (Minor edits, add circuit description, July 2, 2011)
	Iss. 1.7 (Add scope screenshots, July 5, 2011)
	Iss. 1.8 (Minor edits, 18 March 2012)
	Iss. 1.9 (Updates, 19 December 2012)
	Iss. 2.0 (Updated drawings, clarifications, 11 Sep 2014)
	Iss. 2.1 (Testing clarifications and updated sensor installation, 25 Apr 2016)
	Iss. 2.2 (Added images of completed PCB, 06 May 2016)
	Iss. 2.3 (Completed reformat, 11 Jun 2016)
	Iss. 2.4 (Added connector contact images, 17 Jun 2016)
	Iss. 2.5 (Minor edits, 02 Jul 2016)
	Iss. 2.6 (Clarified latching power header, 20 Sep 2017)
	Iss. 2.7 (Corrected power header dwg, 11 Jan 2018)
	Iss. 2.8 (Added to tips lead-free solder, deleted broken links, misc., 16 Feb 2021)
	Iss. 2.9 (Added new PCB, 22 Mar 2021)
	Iss. 3.0 (Corrected conductor quantity in sensor cable, 24 Apr 2021)
	Iss. 3.1 (Added Components ID Guide, 30 Jun 2021)

Note: The basic contents of this construction manual, including SAM logos, were provided by the original designers and used with their permission. Portions of the manual were translated from German. Please let us know if you find errors – send an email to SAMinfo@reeve.com with “SAM Kit” in the subject line (or else your email may be caught by our spam filters).

Total word count: 19070

File size: 12665898B